

KENWOOD

Document Copyrights

Copyright 2006 by Kenwood Corporation. All rights reserved.

No part of this manual may be reproduced, translated, distributed, or transmitted in any form or by any means, electronic, mechanical, photocopying, recording, or otherwise, for any purpose without the prior written permission of Kenwood.

Disclaimer

While every precaution has been taken in the preparation of this manual, Kenwood assumes no responsibility for errors or omissions. Neither is any liability assumed for damages resulting from the use of the information contained herein. Kenwood reserves the right to make changes to any products herein at any time for improvement purposes.

UHF FM TRANSCEIVER

TK-8102

SERVICE MANUAL

REVISED

KENWOOD

© 2001-7 PRINTED IN JAPAN
B51-8585-10 (S) 281

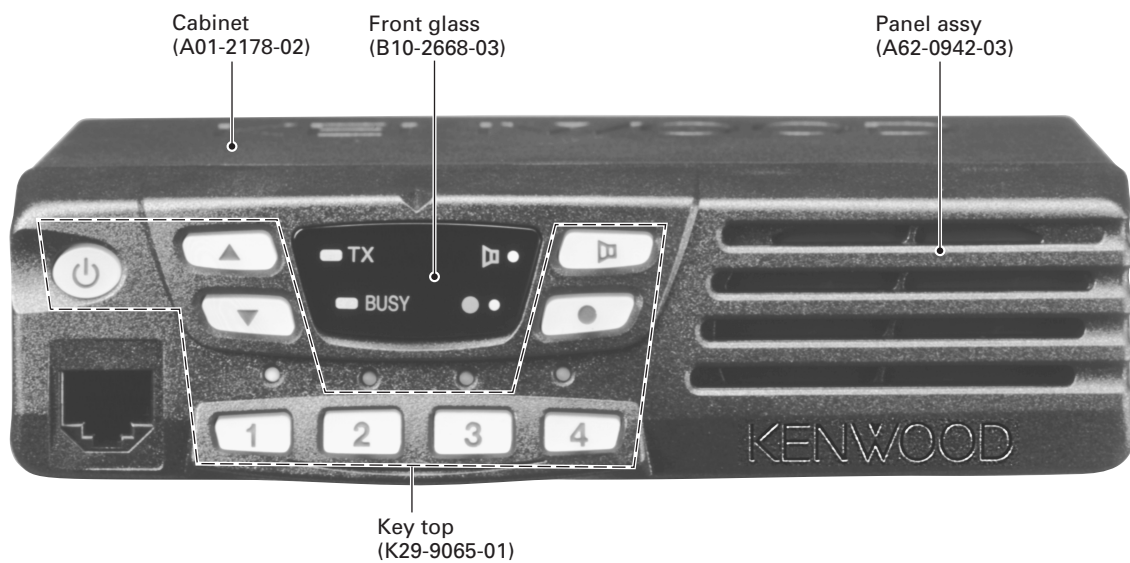

CONTENTS / GENERAL

CONTENTS

GENERAL	2
OPERATING FEATURES	4
REALIGNMENT	7
DISASSEMBLY FOR REPAIR	9
CIRCUIT DESCRIPTION	10
SEMICONDUCTOR DATA	15
DESCRIPTION OF COMPONENTS	16
PARTS LIST	18
EXPLODED VIEW	26
PACKING	27
ADJUSTMENT	28
PC BOARD VIEWS	
DISPLAY UNIT (X54-3340-20)	33
TX-RX UNIT (X57-6300-XX)	35
SCHEMATIC DIAGRAM	41
BLOCK DIAGRAM	45
LEVEL DIAGRAM	47
TERMINAL FUNCTION	49
SPECIFICATIONS	BACK COVER

GENERAL

INTRODUCTION

SCOPE OF THIS MANUAL

This manual is intended for use by experienced technicians familiar with similar types of commercial grade communications equipment. It contains all required service information for the equipment and is current as of this publication date. Changes which may occur after publication are covered by either Service Bulletins or Manual Revisions, which are issued as required.

ORDERING REPLACEMENT PARTS

When ordering replacement parts or equipment information, the full part identification number should be included. This applies to all parts : components, kits, and chassis. If the part number is not known, include the chassis or kit number of which it is a part and a sufficient description of the required component for proper identification.

PERSONNEL SAFETY

The following precautions are recommended for personnel safety :

- DO NOT transmit if someone is within two feet (0.6 meter) of the antenna.
- DO NOT transmit until all RF connectors are secure and any open connectors are properly terminated.
- SHUT this equipment when near electrical blasting caps or while in an explosive atmosphere.
- All equipment should be properly grounded before power-up for safe operation.
- This equipment should be serviced by only qualified technicians.

PRE-INSTALLATION CONSIDERNATIONS

1. UNPACKING

Unpack the radio from its shipping container and check for accessory items. If any item is missing, please contact KENWOOD immediately.

2. LICENSING REQUIREMENTS

Federal regulations require a station license for each radio installation (mobile or base) be obtained by the equipment owner. The licensee is responsible for ensuring transmitter power, frequency, and deviation are within the limits permitted by the station license.

Transmitter adjustments may be performed only by a licensed technician holding an FCC first, second or general class commercial radiotelephone operator's license. There is no license required to install or operate the radio.

GENERAL

3. PRE-INSTALLATION CHECKOUT

3-1. Introduction

Each radio is adjusted and tested before shipment. However, it is recommended that receiver and transmitter operation be checked for proper operation before installation.

3-2. Testing

The radio should be tested complete with all cabling and accessories as they will be connected in the final installation. Transmitter frequency, deviation, and power output should be checked, as should receiver sensitivity, squelch operation, and audio output. QT equipment operation should be verified.

4. PLANNING THE INSTALLATION

4-1. General

Inspect the vehicle and determine how and where the radio antenna and accessories will be mounted.

Plan cable runs for protection against pinching or crushing wiring, and radio installation to prevent overheating.

4-2. Antenna

The favored location for an antenna is in the center of a large, flat conductive area, usually at the roof center. The trunk lid is preferred, bond the trunk lid and vehicle chassis using ground straps to ensure the lid is at chassis ground.

4-3. Radio

The universal mount bracket allows the radio to be mounted in a variety of ways. Be sure the mounting surface is adequate to support the radio's weight. Allow sufficient space around the radio for air cooling. Position the radio close enough to the vehicle operator to permit easy access to the controls when driving.

4-4. DC Power and wiring

1. This radio may be installed in negative ground electrical systems only. Reverse polarity will cause the cable fuse to blow. Check the vehicle ground polarity before installation to prevent wasted time and effort.
2. Connect the positive power lead directly to the vehicle battery positive terminal. Connecting the Positive lead to any other positive voltage source in the vehicle is not recommended.
3. Connect the ground lead directly to the battery negative terminal.
4. The cable provided with the radio is sufficient to handle the maximum radio current demand. If the cable must be extended, be sure the additional wire is sufficient for the current to be carried and length of the added lead.

5. INSTALLATION PLANNING – CONTROL STATIONS

5-1. Antenna system

Control station. The antenna system selection depends on many factors and is beyond the scope of this manual. Your KENWOOD dealer can help you select an antenna system that will best serve your particular needs.

5-2. Radio location

Select a convenient location for your control station radio which is as close as practical to the antenna cable entry point. Secondly, use your system's power supply (which supplies the voltage and current required for your system). Make sure sufficient air can flow around the radio and power supply to allow adequate cooling.

SERVICE

This radio is designed for easy servicing. Refer to the schematic diagrams, printed circuit board views, and alignment procedures contained in this manual.

NOTE

If you do not intend to use the 3.5-mm jack for the external speaker, fit the supplied speaker-jack cap to stop dust and sand getting in.

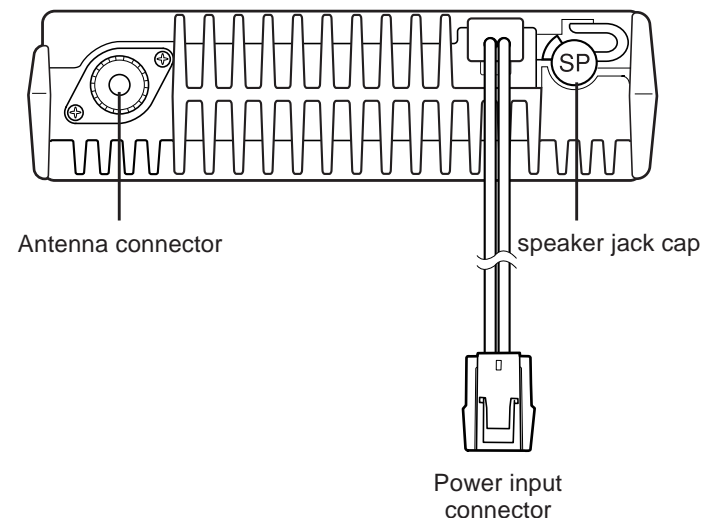

OPERATING FEATURES

1. Controls and Functions

1-1. Front Panel

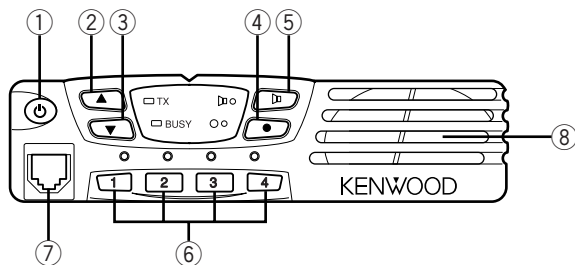

1-2. Microphone

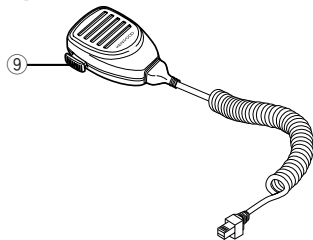

- ① (Power) switch
Press to switch the transceiver ON. Press and hold for approximately 1 seconds to switch the transceiver OFF.
- ② key
Press to increase the volume level.
- ③ key
Press to decrease the volume level.
- ④ key
PF (Programmable Function) key. The default setting of this key is None (no function). The programmable functions available for this key are listed below.
- ⑤ key
PF (Programmable Function) key. The default setting of this key is Monitor (page 5). Other programmable functions available for this key are listed below.
- ⑥ 1/ 2/ 3/ 4 keys
Press to select a channel from 1 to 4.
- ⑦ Microphone jack
Insert the microphone plug into this jack (the microphone is an optional accessory).
- ⑧ Speaker
Internal speaker.
- ⑨ PTT switch
Press this switch, then speak into the microphone to call a station.

1-3. Auxiliary Programmable Functions:

- Emergency
- Key Lock
- Monitor
- None (no function)
- Scan On/OFF
- Talk Around
- Temporary Delete

1-4. Display

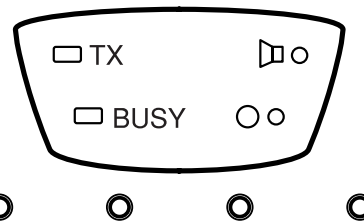

Indicator	Description
	Light while transmitting.
	Lights when a signal is detected on the currently selected channel.
	Lights while the function programmed onto its corresponding key is activated.
	Lights while the function programmed onto its corresponding key is activated.
	Lights to display the currently selected channel (1~ 4)

1-5. Rear panel

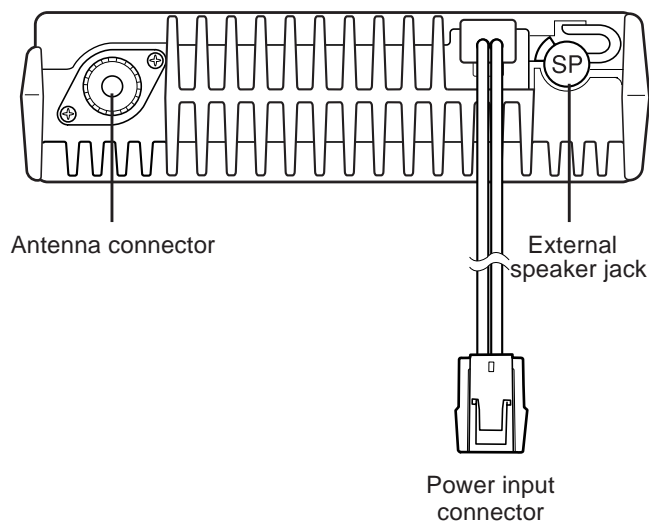

OPERATING FEATURES

2. Operation Features

The TK-8102 is a UHF FM radio designed to operate in conventional format. The programmable features are summarized.

3. Transceiver Controls and Indicators

3-1. Front Panel Controls

All the keys on the front panel are momentary-type push buttons. The functions of these keys are explained below.

- **POWER key**

Transceiver POWER key. When the power is switched off, all the parameters are stored in memory. When the power is switched on again, the transceiver returns to the previous conditions.

- **CHANNEL Keys**

- **MONITOR key (Programmable)**

- **● key (Programmable)**

- **VOLUME UP/DOWN key**

When the key is pressed, the volume level is increased/decreased and repeats if held for 200ms or longer.

- **BUSY/TX LED**

The BUSY indicator (Green LED) shows that the channel is in use. The TX indicator (Red LED) shows that you are transmitting.

3-2. Programmable Keys

The FPU (KPG-70D) enables programmable keys to select the following functions.

- Emergency
- Key Lock
- Monitor
- Scan ON/OFF
- Talk Around
- Temporary Delete
- None

- **Emergency**

Pressing this key for longer than 1 second causes the transceiver to enter the emergency mode. The transceiver jumps to the programmed "Emergency channel" and transmits for 25* seconds.

The transceiver disables mic mute while transmitting. After finishing transmission, the transceiver receives for 5* seconds. The transceiver Mute* the speaker while receiving. Following the above sequence, the transceiver continues to transmit and receive.

* Default value

- **Key lock**

Pressing this key causes the transceiver to accept entry of only the [Vol Up/Down]*, [Key lock], Microphone [PTT], [Monitor], [Emergency], and [Power] keys.

* Programmable

- **Monitor**

Used to release signalling (press once) or squelch (press and hold for approximately two seconds) when operating as a conventional. It is also used to reset option signalling.

- **Scan ON/OFF**

Press this key starts scanning. Pressing this key stops scanning.

- **Talk around**

Press this key, the transceiver uses the receive frequency and the tone for transmission.

The operator can call the other party directly (without repeater). Press this key again, the talk around function goes off.

- **Temporary delete**

The "Add" channel contained in the scan sequence, and "Delete" channel is not contained. In the scan mode, this key switches the channel delete temporarily (Press and hold for approximately one second).

When the transceiver is turned off, the transceiver exits the scan or switches the scan function off.

- **None**

Sounds error operation beep, and no action will occur. Use this function when the transceiver is required to be more simple operated.

4. Scan Operating

■ SCAN start condition

Two or more channels must be added to all channels that can be scanned. The transceiver must be in normal receive mode (PTT off).

When you activate the key programmed to the scan ON/OFF function, the scan starts. The indicator next to the programmed key LED blinks.

■ Scan stop condition

The scan stops temporarily if the following conditions are satisfied.

- 1) A carrier is detected, then QT/DQT matches on channels for which receive the QT/DQT is set by the programming software.
- 2) A carrier is detected on the channels for which receiving QT/DQT is not set by the programming software or when the monitor (signalling cancel) function is activated.

■ Revert channel

The revert channel is used to transmit during scanning and set by the programming software (KPG-70D).

- 1) Selected channel
The transceiver reverts to the channel before scanning or the channel that you changed during scan.
- 2) Selected with talkback
The transceiver reverts to the selected channel prior to scan initiation.
However, if a call is received on a channel other than the selected channel and PTT is pressed before scanning resume, the transceiver "talks back" on the current receive channel.

■ Scan end

When you press the key programmed to the scan function during scan mode, the scan ends.

The indicator next to the programmed key LED turns off.

OPERATING FEATURES

■ Temporary delete

It is possible to delete channel temporary during scan. When scan stops on unnecessary channel for example by interference of the other party, activate the delete function (for example press and hold the key for approximately one second), then that channel is deleted temporarily and scan re-start immediately.

The temporary deleted channels return to pre-set delete/add channels, when the transceiver is turned off or the scan function is switched off.

5. Details of Features

■ Time-out timer

The time-out timer can be programmed in 30 seconds increments from 30 seconds to five minutes and off. If the transmitter is transmitted continuously for longer than the programmed time, the transmitter is disabled and a warning tone sounds while the PTT button is held down. The warning tone stops when the PTT button is released.

■ PTT ID

PTT ID provides a DTMF ANI to be sent with every time PTT (beginning of transmission, end of transmission, or both).

You can program PTT ID "on" or "off" for each channel. The contents of ID are programmed each Radio.

The timing that the transceiver sends ID is programmable.

BOT : DTMF ID (Beginning of TX) is sent on beginning of transmission.

EOT : DTMF ID (End of TX) is sent on end of transmission.

Both : DTMF ID (Beginning of TX) is sent on beginning of transmission and DTMF ID (End of TX) is sent on end of transmission.

■ Off hook decode

If the Off hook decode function has been enabled, removing and replacing the microphone on the hook has no effect for decoding QT/DQT and option signalling.

■ "TOT" pre-alert

The transceiver has "TOT" pre-alert timer. This parameter selects the time at which the transceiver generates "TOT" pre-alert tone before "TOT" is expired.

"TOT" will be expired when the selected time passes from a TOT pre-alert tone.

■ "TOT" re-key time

The transceiver has "TOT" re-key timer. This timer is the time you can not transmit after "TOT" exceeded. After "TOT" re-key time expired you can transmit again.

■ "TOT" reset time

The transceiver has "TOT" reset timer. This timer is the minimum wait time allowed during a transmission that will reset the "TOT" count.

"TOT" reset time causes the "TOT" to continue even after PTT is released unless the "TOT" reset timer has expired.

■ Clear to transpond

The transceiver waits the transpond of DTMF if channel is busy until channel open. This feature prevents the interference to other party.

6. Option Signalling (DTMF)

Built-in DTMF decoder is available for option signalling.

It is possible to use individual call, group call, Stun.

If the option signalling matches, a predetermined action will occur.

If option signalling matches on a channel is set up with option signalling, the channel LED will flash and option signalling will be released. The transpond or alert tone will sound.

While option signalling matches (or if option signalling is deactivated when you are transmitting), you can mute or unmute QT/DQT/Carrier.

■ SP Unmute

You can select the type of SP Unmute system for each channel. The selection is as follows.

Carrier, QT/DQT:

Channel with this option will not check ID Code in order to open its speaker.

Carrier+DTMF, QT/DQT+DTMF:

Channel that is set with this option will have to check for ID Code in order to open its speaker.

Default:

Carrier, QT/DQT.

SP Unmute	Channel Setting		RX Condition	Speaker Condition
	QT/DQT	DTMF		
Carrier	None	None	Carrier	Sounds
		Yes	Carrier Carrier+DTMF	Sounds
Carrier+DTMF	None	Yes	Carrier	Not Sounds
			Carrier+DTMF	Sounds
QT/DQT	Yes	None	Carrier	Not Sounds
			Carrier+QT/DQT	Sounds
		Yes	Carrier	Not Sounds
			Carrier+QT/DQT Carrier+QT/DQT+DTMF Carrier+DTMF	Sounds Sounds Not Sounds
QT/DQT+DTMF	Yes	Yes	Carrier	Not Sounds
			Carrier+QT/DQT	Not Sounds
			Carrier+QT/DQT+DTMF	Sounds
			Carrier+DTMF	Not Sounds

Note:

When QT/DQT is not used, QT/DQT and QT/DQT+DTMF can not be selected.

When DTMF is not used, Carrier+DTMF and QT/DQT+DTMF can not be selected.

■ Auto Reset

If option signalling matches a group set up with option signalling, option signalling is released. After matching option signalling, option signalling will temporarily reset automatically.

OPERATING FEATURES / REALIGNMENT

■ Stun

If the stun code matches, a predetermined action will occur. Whether option signalling is activated or not, when stun matches on any channel, the transceiver will become TX inhibited or TX/RX inhibited. While stun is active, if the stun code + "#" code is received, stun will deactivate.

When stun matches, transpond will function. Alert will not be output.

7. Audible User Feedback Tones

The transceiver outputs various combinations of tones to notify the user of the transceiver operating state.

Refer to the help file on the KPG-70D, regarding the functions that are not listed below.

■ Stun on tone

When a stun code is received, transpond tone sounds.

■ Stun off tone

When a stun release code is received, transpond tone sounds.

■ Group call tone

Sounds when a group call with the correct DTMF option signalling is received, repeats 7 times. You can select yes or no in the Alert tone level setting.

■ Individual call tone

Sounds when an individual call with the correct DTMF option signalling is received. You can select yes or no in the Alert tone level setting.

■ Key input error tone

Sounds when a key is pressed but that key cannot be used. You can select yes or no for the optional feature's warning tone.

■ Transpond tone

Sounds when an individual call with the correct DTMF option signalling is received. For group calls, only the group tone will sound, not the transpond tone.

■ Pre alert tone

Sounds prior to the TOT TX inhibit activation. If TOT pre alert is set, the tone sounds at the amount of time programmed, before the TOT expires (TOT time – TOT pre alert time = Pre alert tone sounding time). You can select yes or no for the optional feature's warning tone.

■ Transmit protection

The power module is protected against heat while transmitting by making the radio cuts down TX power when the temperature of the power module becomes higher than reference. After that, if the temperature continue to rise, transmission is stopped. The power module is also protected against over voltage by having the radio to check that the voltage of power supply connected to the radio is not higher than about 17V when the radio is turned on, otherwise it can not transmit. In both cases when transmission is stopped, a beep will continue to sound until the PTT key is released.

REALIGNMENT

1. Modes

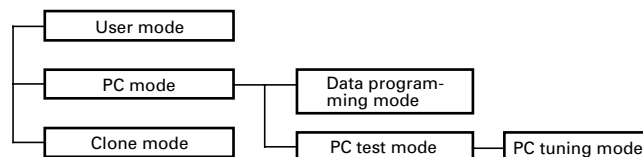

Mode	Function
User mode	For normal use.
PC mode	Used for communication between the radio and PC (IBM compatible).
Data programming mode	Used to read and write frequency data and other features to and from the radio.
PC test mode	Used to check the radio using the PC. This feature is included in the FPU.
PC tuning mode	Used to tune the radio using the PC.
Clone mode	Used to transfer programming data from one radio to another.

2. How to Enter Each Mode

Mode	Operation
User mode	Power ON
PC mode	Received commands from PC
Clone mode	[1]+Power ON (Two seconds)

3. PC Mode

3-1. Preface

The TK-8102 transceiver is programmed using a personal computer, a programming interface (KPG-46) and programming software (KPG-70D).

The programming software can be used with an IBM PC or compatible. Figure 1 shows the setup of an IBM PC for programming.

3-2. Connection Procedure

1. Connect the TK-8102 to the personal computer with the interface cable.
2. When the Power is switched on, user mode can be entered immediately. When the PC sends a command, the radio enters PC mode.
When data is transmitted from transceiver, the red LED blink.
When data is received by the transceiver, the green LED blink.
In the PC mode, 4CH LEDs, [MON] LED and [●] LED are turned on.

Notes :

- The data stored in the personal computer must match model type when it is written into the EEPROM.
- Attach the interface cable, then change the TK-8102 to PC mode.

REALIGNMENT

3-3. KPG-46 Description

(PC programming interface cable : Option)

The KPG-46 is required to interface the TK-8102 to the computer. It has a circuit in its D-subconnector (25-pin) case that converts the RS-232C logic level to the TTL level.

The KPG-46 connects the modular microphone jack of the TK-8102 to the computers RS-232C serial port.

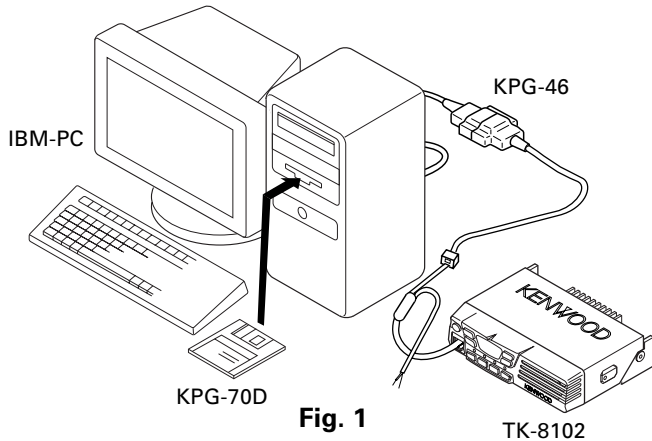

Fig. 1

3-4. Programming Software Description

The KPG-70D programming disk is supplied in 3-1/2" disk format. The software on this disk allows a user to program TK-8102 radio via a programming interface cable (KPG-46).

3-5. Programming With IBM PC

If data is transferred to the transceiver from an IBM PC with the KPG-70D, the destination data (basic radio information) for each set can be modified.

4. Clone Mode

Programming data can be transferred from one radio to another by connecting them via their modular microphone jacks. The operation is as follows (the transmit radio is the master and the receive radio is the slave).

NOTE: Clone mode should enabled.

1. Turn the master TK-8102 power ON with the [1] key held down. The TK-8102 [●] LED is turned on.
2. Power on the slave TK-8102.
3. Connect the cloning cable (No. E30-3382-05) to the modular microphone jacks on the master and slave.
4. Press the [●] key on the master TK-8102 transceiver. The data of the master is sent to the slave. While the master is sending data, [TX] LED blinked. While the slave is receiving the data, 4 LEDs, [MON] LED, [●] LED are turned on and [BUSY] LED blinked. When cloning of data is completed, the master [TX] LED turned off, and the slave automatically operates in the User mode. The slave can then be operated by the same program as the master.
5. The other slave can be continuously cloned. Carry out the operation in step 2 to 4.

Adding the data password.

If the data password is set in the optional feature menu, you must enter the password (Master transceiver) to activate a clone mode.

you can use 1, 2, 3, and 4 to configure the password. The maximum length of the password is 10 digits.

1. [1]+Power ON.
2. [1]~[4] LED, and MON LED are turned ON.
3. Enter the password using [1]~[4] keys.
4. Press [MON] key.
5. If the password matches, the transceiver enters a clone mode. Otherwise, transceiver beeps and returns to the password input mode.

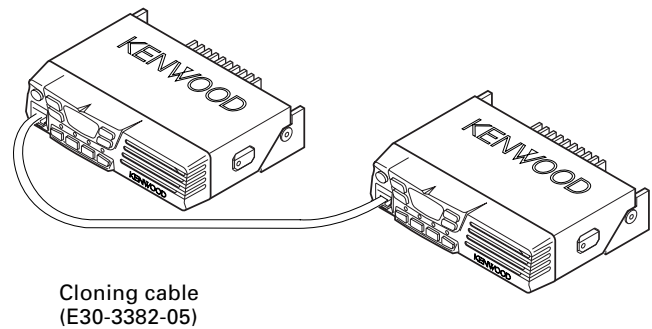

Fig. 2

DISASSEMBLY FOR REPAIR

1. When you remove the panel, turn the transceiver up side down. Detach the panel by lifting the tabs as shown below.

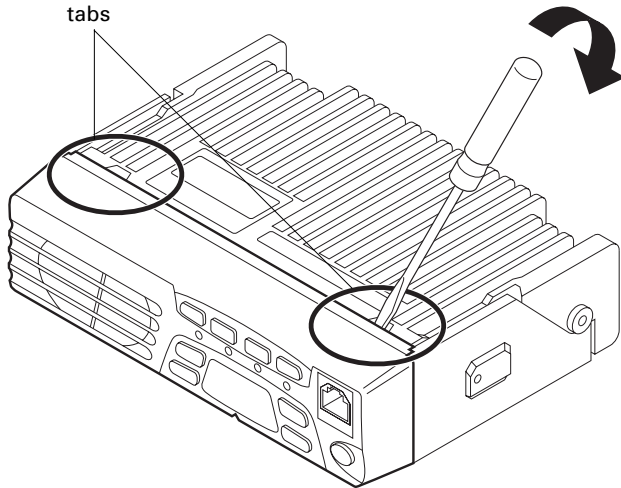

Fig. 1

3. To remove the display unit PCB, detach the PCB by lifting at the indents of the PCB as shown below.

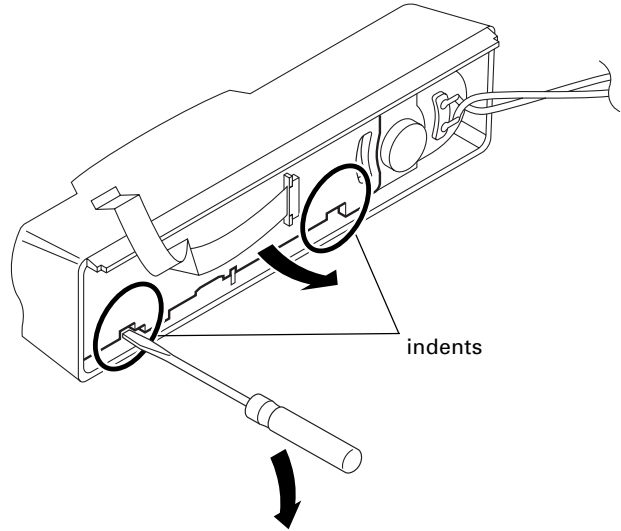

Fig. 3

2. To remove the cabinet, first turn the transceiver up side down. Detach the cabinet by prying the tabs as shown below.

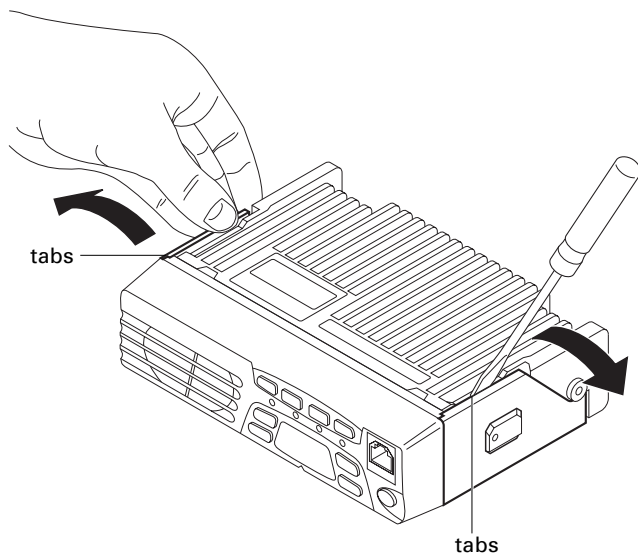

Fig. 2

4. When mounting the front panel, match the 4 tabs of the chassis with the panel, being sure they attach securely.

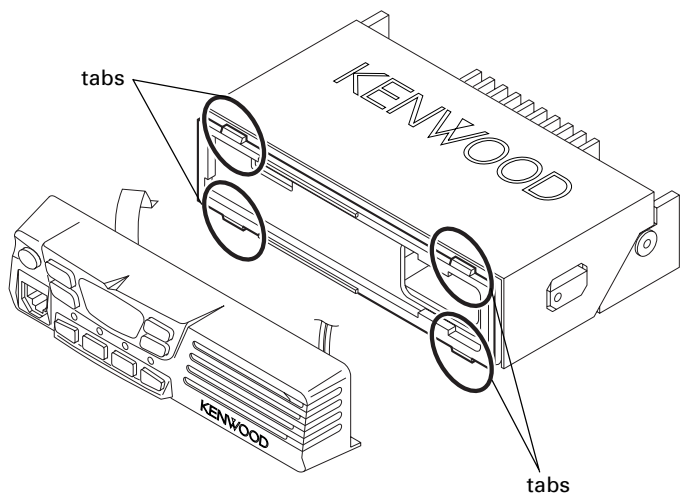

Fig. 4

CIRCUIT DESCRIPTION

Frequency Configuration

The receiver utilizes double conversion. The first IF is 49.95MHz and the second IF is 450kHz. The first local oscillator signal is supplied from the PLL circuit.

The PLL circuit in the transmitter generates the necessary frequencies. Figure 1 shows the frequencies.

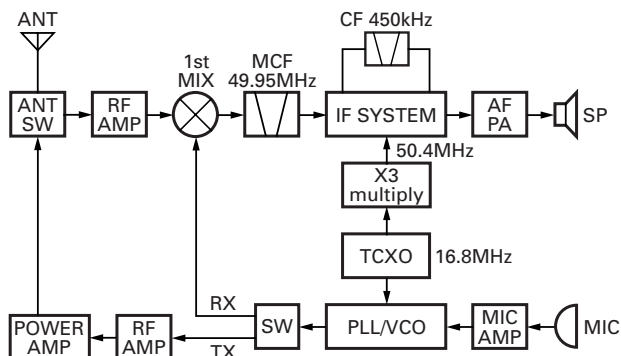

Fig. 1 Frequency configuration

Receiver System

The receiver is double conversion superheterodyne. The frequency configuration is shown in Figure 1.

■ Front-end RF Amplifier

An incoming signal from the antenna is applied to an RF amplifier (Q26) after passing through a transmit/receive switch circuit (D31 and D32 are off) and a BPF (L36, L38, L48, L49 and varactor diodes: D25, D26, D28). After the signal is amplified (Q26), the signal is filtered by a BPF (L30, L32 and varactor diodes: D21, D22) to eliminate unwanted signals before it is passed to the first mixer.

The voltage of these diodes are controlled by tracking the CPU (IC6) center frequency of the band pass filter. (See Fig. 2)

■ First Mixer

The signal from the RF amplifier is heterodyned with the first local oscillator signal from the PLL frequency synthesizer circuit at the first mixer (Q21) to create a 49.95MHz first intermediate frequency (1st IF) signal. The first IF signal is then fed through two monolithic crystal filters (MCFs : XF1) to further remove spurious signals.

■ IF Amplifier

The first IF signal is amplified by Q19, and the enters IC5 (FM processing IC). The signal is heterodyned again with a second local oscillator signal within IC5 to create a 450kHz second IF signal. The second IF signal is then fed through a 450kHz ceramic filter (Wide : CF1, Narrow : CF2) to further eliminate unwanted signals before it is amplified and FM detected in IC5.

Item	Rating
Nominal center frequency	49.95MHz
Pass bandwidth	±5.0kHz or more at 3dB
35dB stop bandwidth	±20.0kHz or less
Ripple	1.0dB or less
Insertion loss	5.0dB or less
Guaranteed attenuation	80dB or more at fo±1MHz Spurious : 40dB or more within fo±1MHz
Terminal impedance	350Ω / 5.5pF

Table 1 Crystal filter (L71-0591-05) : XF1

Item	Rating
Nominal center frequency	450kHz
6dB bandwidth	±6.0kHz or more
50dB bandwidth	±12.5kHz or less
Ripple	2.0dB or less
Insertion loss	6.0dB or less
Guaranteed attenuation	35.0dB or more within fo±100kHz
Terminal impedance	2.0kΩ

Table 2 Ceramic filter (L72-0993-05) : CF1

Item	Rating
Nominal center frequency	450kHz
6dB bandwidth	±4.5kHz or more
50dB bandwidth	±10.0kHz or less
Ripple	2.0dB or less
Insertion loss	6.0dB or less
Guaranteed attenuation	55.0dB or more within fo±100kHz
Terminal impedance	2.0kΩ

Table 3 Ceramic filter (L72-0994-05) : CF2

Item	Rating
Nominal center frequency	450kHz
6dB bandwidth	±4.5kHz or more
50dB bandwidth	±10.0kHz or less
Ripple	2.0dB or less
Insertion loss	6.0dB or less
Guaranteed attenuation	60.0dB or more within fo±100kHz
Terminal impedance	2.0kΩ

Table 4 Ceramic filter (L72-0999-05) : CF2

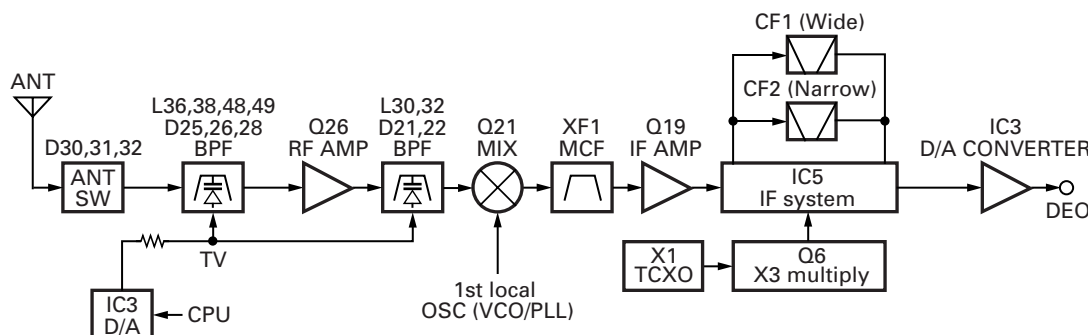

Fig. 2 Receiver system

CIRCUIT DESCRIPTION

Wide/Narrow Changeover Circuit

The Wide port (pin 92) and Narrow port (pin 91) of the CPU is used to switch between ceramic filters. When the Wide port is high, the ceramic filter SW diodes (D13, D15) cause CF1 to turn on to receive a Wide signal.

When the Narrow port is high, the ceramic filter SW diodes (D13, D15) cause CF2 to turn on to receive a Narrow signal.

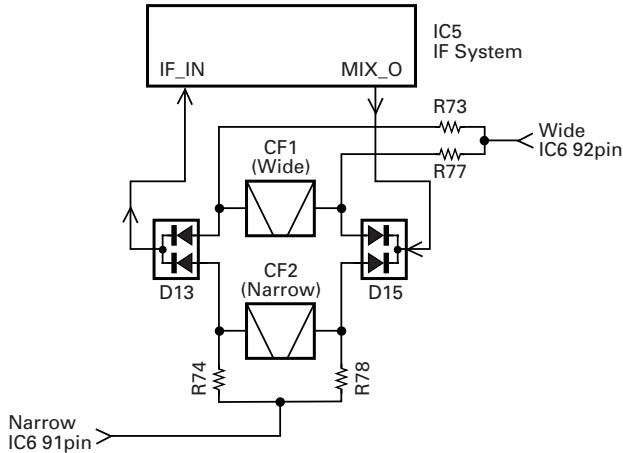

Fig. 3 Wide/Narrow changeover circuit

AF Signal System

The detection signal from IF IC (IC5) goes to D/A converter (IC3) to adjust the gain and is output to AF filter (IC10) for characterizing the signal. The AF signal output from IC10 and the DTMF signal, BEEP signal are summed and the resulting signal goes to the D/A converter (IC3). The AFO output level is adjusted by the D/A converter. The signal output from the D/A converter is input to the audio power amplifier (IC102). The AF signal from IC102 switches between the internal speaker and speaker jack (J1) output.

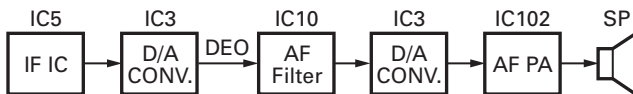

Fig. 4 AF signal system

Squelch Circuit

The detection output from the FM IF IC (IC5) passes through a noise amplifier (Q18) to detect noise. A voltage is applied to the CPU (IC6). The CPU controls squelch according to the voltage (SQIN) level. The signal from the RSSI pin of IC5 is monitored. The electric field strength of the receive signal can be known before the SQIN voltage is input to the CPU, and the scan stop speed is improved.

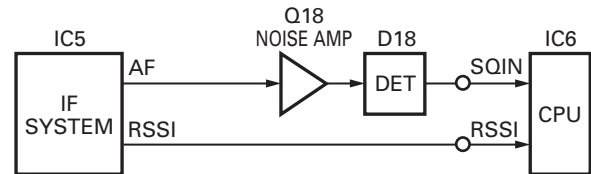

Fig. 5 Squelch circuit

PLL Frequency Synthesizer

The PLL circuit generates the first local oscillator signal for reception and the RF signal for transmission.

PLL

The frequency step of the PLL circuit is 5 or 6.25kHz. A 16.8MHz reference oscillator signal is divided at IC1 by a fixed counter to produce the 5 or 6.25kHz reference frequency. The voltage controlled oscillator (VCO) output signal is buffer amplified by Q15, then divided in IC1 by a dual-module programmable counter. The divided signal is compared in phase with the 5 or 6.25kHz reference signal in the phase comparator in IC1. The output signal from the phase comparator is filtered through a low-pass filter and passed to the VCO to control the oscillator frequency. (See Fig. 6)

VCO

The operating frequency is generated by Q11 in transmit mode and Q10 in receive mode. The oscillator frequency is controlled by applying the VCO control voltage, obtained from the phase comparator, to the varactor diodes (D10 and D12 in transmit mode and D9 and D11 in receive mode). The TX/RX pin is set low in receive mode causing Q12 and Q7 to turn Q11 off, and turn Q10 on. The TX/RX pin is set high in transmit mode. The outputs from Q10 and Q11 are amplified by Q15 and sent to the RF amplifiers.

CIRCUIT DESCRIPTION

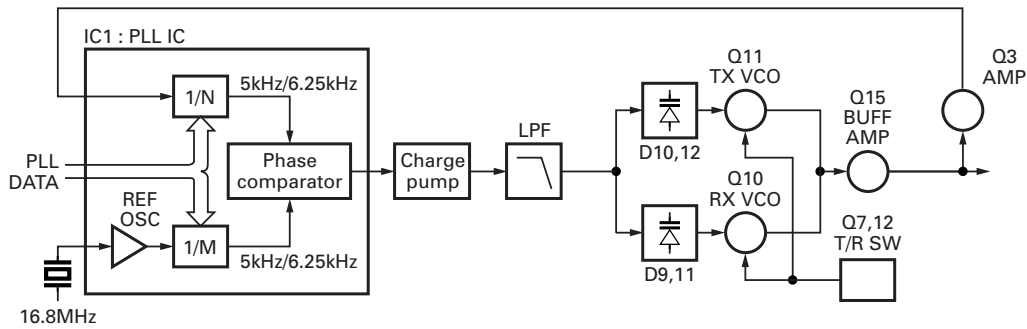

Fig. 6 PLL circuit

■ Unlock Circuit

During reception, the 8RC signal goes high, the 8TC signal goes low, and Q29 turns on. Q31 turns on and a voltage is applied to the collector (8R). During transmission, the 8RC signal goes low, the 8TC signal goes high and Q30 turns on. Q33 turns on and a voltage is applied to 8T.

The CPU in the control unit monitors the PLL (IC1) LD signal directly. When the PLL is unlocked during transmission, the PLL LD signal goes low. The CPU detects this signal and makes the 8TC signal low. When the 8TC signal goes low, no voltage is applied to 8T, and no signal is transmitted.

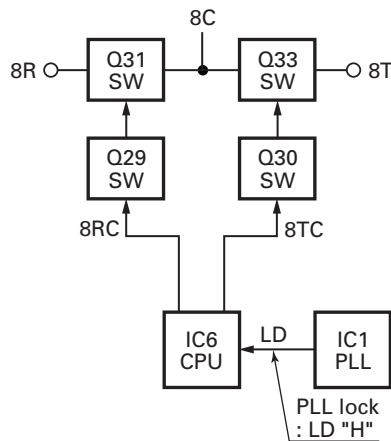

Fig. 7 Unlock circuit

Transmitter System

■ Outline

The transmitter circuit produces and amplifies the desired frequency directly. It FM-modulates the carrier signal by means of a varicap diode.

■ Power Amplifier Circuit

The transmit output signal from the VCO passes through the transmission/reception selection diode (D19) and amplified to a specified level of the power module (IC101) by the drive block (Q23, Q25 and Q39). The amplified signal goes to a low-pass filter. The low-pass filter removes unwanted high-frequency harmonic components, and the resulting signal is goes the antenna terminal.

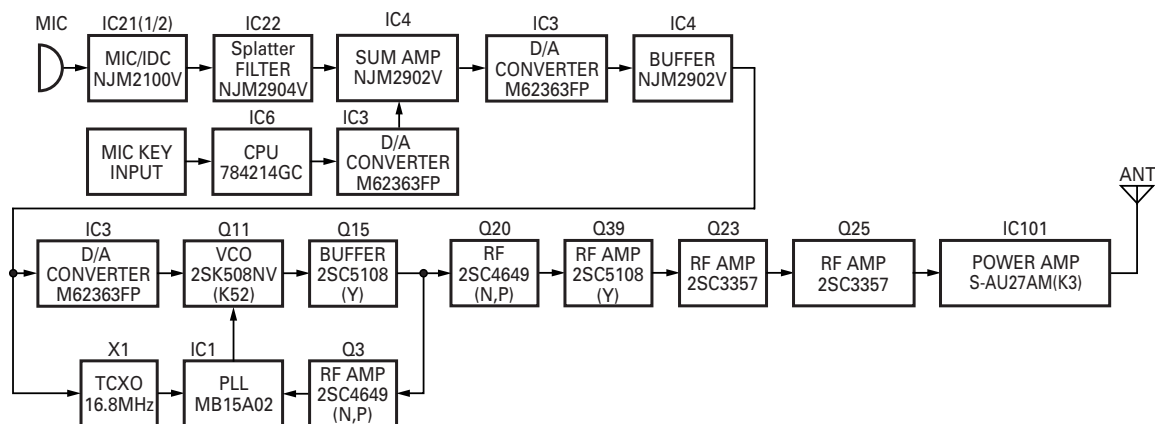

Fig. 8 Transmitter system

CIRCUIT DESCRIPTION

■ APC Circuit

The automatic transmission power control (APC) circuit detects part of a power module output with a diode (D34, D36) and applies a voltage to IC12. IC12 compares the APC control voltage (PC) generated by the D/A converter (IC3) and DC amplifier (IC4) with the detection output voltage to control Q27 and Q101, generates DB voltage from B voltage, and stabilizes transmission output.

The APC circuit is configured to protect over current of the power module due to fluctuations of the load at the antenna end and to stabilize transmission output at voltage and temperature variations.

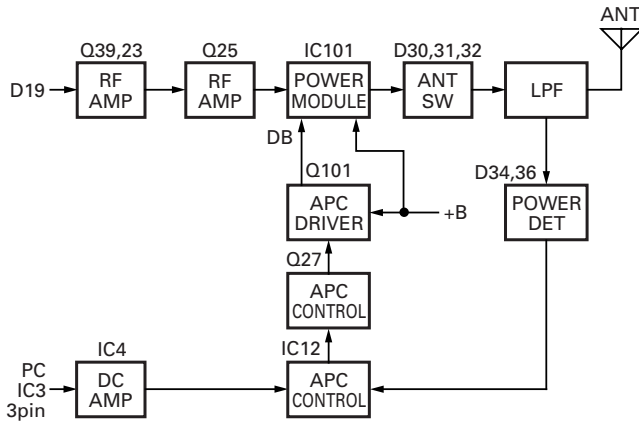

Fig. 9 APC circuit

Control Circuit

The CPU carries out the following tasks:

- 1) Controls the WIDE, NARROW, TX/RX outputs.
- 2) Adjusts the AF signal level of the AF filter (IC10) and turns the filter select compounder on or off.
- 3) Controls the DTMF decoder (IC9).
- 4) Controls the display unit.
- 5) Controls the PLL (IC1).
- 6) Controls the D/A converter (IC3) and adjusts the volume, modulation and transmission power.

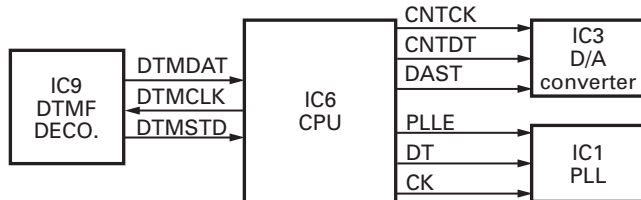

Fig. 10 Control circuit

■ Memory Circuit

The transceiver has an 8k-bit EEPROM (IC7). The EEPROM contains adjustment data. The CPU (IC6) controls the EEPROM through three serial data lines.

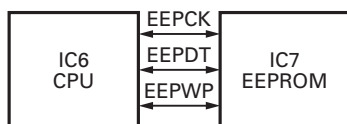

Fig. 11 Memory circuit

■ Display Circuit

The CPU (IC6) controls the display LEDs. When the transceiver is busy, the LEDG line goes high, Q4 turns on and the green LED (D11) lights. In transmit mode, the LEDR line goes high, Q8 turns on and the red LED (D12) lights. Backlit LEDs (D1~D4) are provided.

When a function key (MON, PF, C1, C2, C3 or C4) is selected, its respective line goes high (LED MON, LED PF, LED C1, LED C2, LED C3 or LED C4), the switch connected to that line turns on and the amber LED lights.

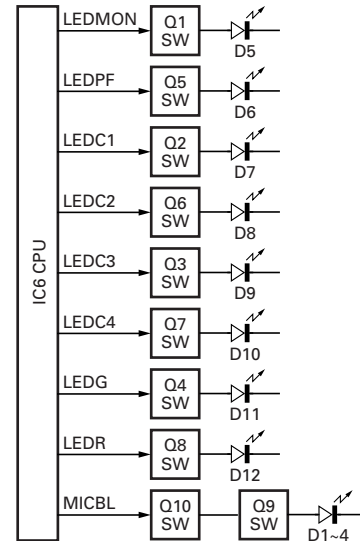

Fig. 12 Display circuit

■ Key Matrix Circuit

The TK-8102 front panel has function keys. Each of them is connected to a cross point of a matrix of the KMI1 to KMO2 ports of the microprocessor. The KMO1 to KMO2 ports are always high, while the KMI1 to KMI4 ports are always low.

The microprocessor monitors the status of the KMI1 to KMO2 ports. If the state of one of the ports changes, the microprocessor assumes that the key at the matrix point corresponding to that port has been pressed.

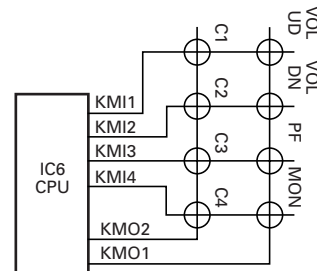

Fig. 13 Key matrix circuit

CIRCUIT DESCRIPTION

■ Encode

The QT and DQT signals are output from QT/DQT of the CPU (IC6) and summed with the external pin DI line by the summing amplifier (IC4) and the resulting signal goes to the D/A converter (IC3). The DTMF and signal is output from DTMF of the CPU and goes to the DIA converter (IC3). The signal is summed with a MIC signal by the summing amplifier (IC4), and the resulting signal goes to the D/A converter (IC3).

The D/A converter (IC3) adjusts the MO level and the balance between the MO and QT/DQT levels. Part of a QT/DQT signal is summed with MO and the resulting signal goes to the VCOMOD pin of the VCO. This signal is applied to a varicap diode in the VCO for direct FM modulation.

■ Decode

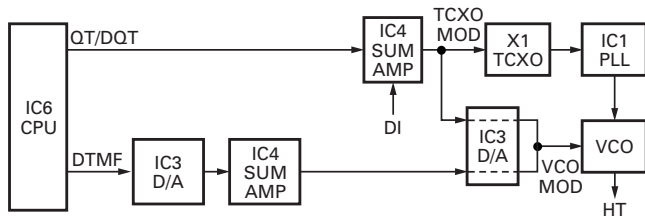

Fig. 14 Encode

• QT/DQT/DTMF

The signal (DEO) passes through two low-pass filters of IC11, goes to QTIN of the CPU (IC6) to decode QT, DQT. The DTMF signal is decoded by a dedicated IC (IC9) and the resulting signal is sent to the CPU (IC6) as serial data.

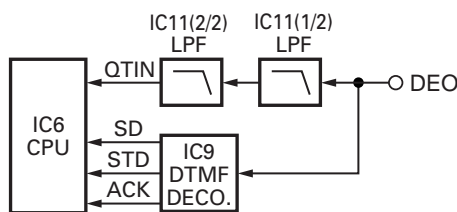

Fig. 15 Decode

■ D/A Converter

The D/A converter (IC3) is used to adjust MO modulation, AF volume, TV voltage, FC reference voltage, and PC POWER CONTROL voltage level.

Adjustment values are sent from the CPU as serial data. The D/A converter has a resolution of 256 and the following relationship is valid:

$$\text{D/A output} = (\text{Vin} - \text{VDAREf}) / 256 \times n + \text{VDAREf}$$

Vin: Analog input

VDAREf: D/A reference voltage

n: Serial data value from the microprocessor (CPU)

Power Supply Circuit

When the POWER switch on the display unit is pressed, the power port on the display unit which is connected to CPU port 18 (POWER), goes low, then CPU port 93 (SBC) goes high, Q34 turns on, SB SW (Q42) turns on and power (SB) is supplied to the radio.

This circuit has an overvoltage protection circuit. If a DC voltage of 18 V or higher is applied to the power cable, D39 turns on and a voltage is applied to the base of Q38. This voltage turns Q38 on and turns Q34 and SB off.

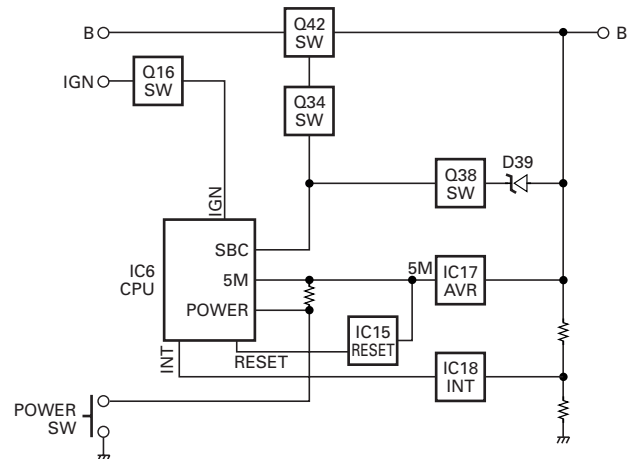

Fig. 16 Power supply circuit

SEMICONDUCTOR DATA

Microprocessor : 784214AGCXXX (TX-RX Unit IC6)

■ Terminal function

Pin No.	Name	I/O	Function	Pin No.	Name	I/O	Function
1	NC	I		48	FNC8	I/O	Function Port8
2	DTMOSC	O	DTMF IC Clock Control	49	NC	I	
3	PLLE	O	PLL IC Chip Select	50	MUTE1	O	AF Mute
4	EVLDD	O	E-Volume LD	51	MUTE2	O	Speaker Mute
5	DTMCK	O	DTMF Dec IC Clock	52	MUTE3	O	AF AMP SW
6	DTMDT	I/O	DTMF Dec IC Data	53	DT	O	Common Data
7	UL	O	Unlock Detect	54	CK	O	Common Clock
8	BSHIFT	O	Clock Shift	55	NC	I	
9	VDD	-		56	EEPCK	O	EEPROM Clock
10	X2	-	X'TAL(7.3728MHz)	57	EEPDT	I/O	EEPROM Data
11	X1	-	X'TAL(7.3728MHz)	58	EEPWT	O	EED Write Protect
12	VSS	-	GND	59	DST1	I	Destination 1
13	NC	-	OPEN	60	DST2	I	Destination 2
14	NC	-	GND	61	DST3	I	Destination 3 (Open)
15	RESET	-	CPU RESET	62	NC	I	
16	INT	I	uCOM Stop	63	24VDET	I	24V Detect
17	DMTSDT	I	DTMF Dec IC STD	64	NC	I	
18	POWER	I	Power Key Input	65	LEDC1	O	LED for CH1 Key
19	IGN	I	Ignition	66	LEDC2	O	LED for CH2 Key
20	TX/RX	O	TX/RX	67	LEDR	O	TX LED
21	LEDMON	O	LED for MON Key	68	LEDG	O	Busy LED
22	LEDPF	O	LED for PF Key	69	MICBL	O	Mic Back Light
23	AVDD	-	+5V	70	LEDC3	O	LED for CH3 Key
24	AVREF	-	+5V	71	LEDC4	O	LED for CH4 Key
25	QTIN	I	QT/DQT Input	72	VSS	-	GND
26	SQIN	I	Squelch Input	73	MICMT	O	Mic1 Mute
27	RSSI	I	RSSI Input	74	MICEM	O	Mic2 Mute
28	PWRPRCT	I	Power Protect	75	NC	I	
29	BATT	I	Battery Voltage	76	8RC	O	8R Control
30	TEMP1	I	Temperature1	77	8TC	O	8T Control
31	TEMP2	I	Temperature2	78	CM	I/O	Mic Key Check
32	TEMP3	I	Temperature3	79	NC	I	
33	AVSS	-	GND	80	NC	I	
34	DTM/BEEP	O	DTMF/Beep Output	81	VDD5M	-	+5V
35	QT/DQT	O	QT/DQT Output	82~85	NC	I	
36	AVREF	-	+5V	86	KMI1	I	Key Matrix Input1
37	FNC1	I/O	Function Port1	87	KMI2	I	Key Matrix Input2
38	FNC2	I/O	Function Port2	88	KMI3	I	Key Matrix Input3
39	HOOK	I	Hook	89	KMI4	I	Key Matrix Input4
40	RXD	I	From FPU	90	NC	I	
41	TXD	O	To FPU	91	NARROW	O	Wide / Narrow2
42	PTT	I	PTT Key	92	WIDE	O	Wide / Narrow
43	FNC3	I/O	Function Port3	93	SBC	O	Battery Switch
44	FNC4	I/O	Function Port4	94	FLASH	-	Flash Write Port
45	FNC5	I/O	Function Port5	95~98	NC	I	
46	FNC6	I/O	Function Port6	99	KMO1	O	Key Matrix Output1
47	FNC7	I/O	Function Port7	100	KMO2	O	Key Matrix Output2

DESCRIPTION OF COMPONENTS

Display Unit (X54-3340-20)

SYMBOL	PARTS NAME	DISCRIPTION
D1~4	LED	KEY BACKLIT
D5	LED	MONITOR KEY LIGHT
D6	LED	PROGRAMMABLE KEY LIGHT
D7~10	LED	CHANNEL KEY LIGHT
D11	LED	BUSY
D12	LED	TRANSMIT
Q1	TRANSISTOR	MONITOR KEY LIGHT SW
Q2,3	TRANSISTOR	CHANNEL KEY LIGHT SW
Q4	TRANSISTOR	BUSY LIGHT SW
Q5	TRANSISTOR	PROGRAMMABLE KEY LIGHT SW
Q6,7	TRANSISTOR	CHANNEL KEY LIGHT SW
Q8	TRANSISTOR	TRANSMIT LIGHT SW
Q9,10	TRANSISTOR	KEY BACKLIT SW

TX-RX Unit (X57-6300-XX)

Ref. No.	Use/Function	Operation/Condition
D1	DIODE	SURGE ABSORPTION /PTT
D2	DIODE	SURGE ABSORPTION /HOOK
D3	DIODE	SURGE ABSORPTION /MICBL
D4	DIODE	SURGE ABSORPTION /CM
D6	DIODE	DC SWITCH
D7	DIODE	VOTAGE DROPPED
D9	VARICAP	RX VCO
D10	VARICAP	TX VCO
D11	VARICAP	RX VCO
D12	VARICAP	TX VCO
D13	DIODE	IF SWITCH (WIDE/NARROW)
D14	VARICAP	MODULATION
D15	DIODE	IF SWITCH (WIDE/NARROW)
D16	DIODE	LIPPLE FILTER
D18	DIODE	DETECTION
D19	DIODE	RF SWITCH(TX/RX)
D21	VARICAP	RF BPF TUNING
D22	VARICAP	RF BPF TUNING
D23	DIODE	TEMPERATURE COMPENSATION
D24	DIODE	LIMITTER
D25	VARICAP	RF BPF TUNING
D26	VARICAP	RF BPF TUNING
D27	DIODE	TEMPERATURE COMPENSATION
D28	VARICAP	RF BPF TUNING
D30	DIODE	ANT SW
D31	DIODE	ANT SW

Ref. No.	Use/Function	Operation/Condition
D32	DIODE	ANT SW
D34	DIODE	APC VOLTAGE DETECT
D36	DIODE	APC VOLTAGE DETECT
D38	DIODE	REVERSE CONNECT PROTECTION
D39	DIODE	OVER VOLTAGE DETECTION
D41	POLY SW	CURRENT PROTECTION
D43	DIODE	OR GATE /Mic Mute, AGC
D44	DIODE	AGC
Q2	FET	MIC MUTE /Active while MICEM is H
Q3	TRANSISTOR	RF AMP /PLL Fin
Q4	TRANSISTOR	CHARGE PUMP
Q5	TRANSISTOR	CHARGE PUMP
Q6	TRANSISTOR	BUFFER AMP /16.8MHz 3rd over tone
Q7	FET	T/R SW
Q10	FET	RX VCO
Q11	FET	TX VCO
Q12	TRANSISTOR	T/R SW
Q13	TRANSISTOR	BEAT SHIFT /Active while Beat shift is on
Q14	TRANSISTOR	LIPPLE FILTER
Q15	TRANSISTOR	BUFFER AMP /Output of VCO
Q16	TRANSISTOR	IGNITION /Ignition Sens.
Q18	TRANSISTOR	NOISE AMP
Q19	TRANSISTOR	IF AMP
Q20	TRANSISTOR	RF AMP /Output of VCO
Q21	FET	MIXER
Q22	FET	AF MUTE /Active while Mute1 is H
Q23	TRANSISTOR	RF AMP /Drive stage
Q24	TRANSISTOR	BUFFER AMP /RX Audio
Q25	TRANSISTOR	RF AMP /Drive stage
Q26	FET	RF AMP /LNA
Q27	TRANSISTOR	APC CONTROL
Q29	TRANSISTOR	DC SWITCH(8R) /Active while RX
Q30	TRANSISTOR	DC SWITCH(8T) /Active while TX
Q31	TRANSISTOR	DC SWITCH(8R) /Active while RX
Q32	TRANSISTOR	AF MUTE /Active while Mute2 is H
Q33	TRANSISTOR	DC SWITCH(8T) /Active while TX

DESCRIPTION OF COMPONENTS

Ref. No.	Use/Function	Operation/Condition
Q34	TRANSISTOR	DC SWITCH(SB) /Active when power on
Q35	TRANSISTOR	AF MUTE /Active while Mute3 is H
Q37	TRANSISTOR	BEAT SHIFT /Active while Beat shift is on
Q38	TRANSISTOR	OVER VOLTAGE DETECTION /Active while PS voltage is more than 18V
Q39	TRANSISTOR	RF AMP /Drive stage
Q41	TRANSISTOR	MIC MUTE /Emergency Mic mute
Q42	TRANSISTOR	DC SWITCH(SB) /Active when power on
Q43	FET	AF MUTE Active while Mute1 is H
Q101	TRANSISTOR	APC DRIVER
IC1	IC	PLL SYNTHESIZER
IC3	IC	D/A CONVERTER
IC4	IC	BUFFER AMP / SUM AMP / DC AMP / 1/2V _{cc}
IC5	IC	IF DEMODULATION
IC6	IC	CPU
IC7	IC	EEPROM
IC9	IC	DTMF DECODE
IC10	IC	AUDIO FILTER
IC11	IC	ACTIVER FILTER (QT/DQT)
IC12	IC	APC CONTROL
IC14	IC	VOLTAGE REGULATOR (5C)
IC15	IC	VOLTAGE DETECTOR RESET
IC17	IC	VOLTAGE REGULATOR (5M)
IC18	IC	VOLTAGE DETECTOR INT
IC19	IC	DIVIDER (7.159MHz)
IC20	IC	VOLTAGE REGULATOR (8C)
IC21	IC	MIC AMP / IDC
IC22	IC	SPLATTER FILTER
IC101	IC	POWER MODULE
IC102	IC	AF POWER AMP

PARTS LIST

CAPACITORS

CC 45 TH 1H 220 J
 1 2 3 4 5 6

- 1 = Type ... ceramic, electrolytic, etc.
- 2 = Shape ... round, square, ect.
- 3 = Temp. coefficient
- 4 = Voltage rating
- 5 = Value
- 6 = Tolerance

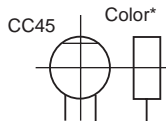

Capacitor value

- 010 = 1pF
- 100 = 10pF
- 101 = 100pF
- 102 = 1000pF = 0.001μF
- 103 = 0.01μF

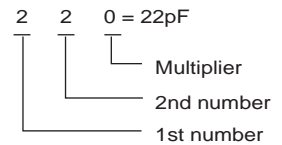

Temperature coefficient

1st Word	C	L	P	R	S	T	U
Color*	Black	Red	Orange	Yellow	Green	Blue	Violet
ppm/°C	0	-80	-150	-220	-330	-470	-750

2nd Word	G	H	J	K	L
ppm/°C	±30	±60	±120	±250	±500

Example : CC45TH = -470 ± 60ppm/°C

Tolerance (More than 10pF)

Code	C	D	G	J	K	M	X	Z	P	No code
(%)	±0.25	±0.5	±2	±5	±10	±20	+40 -40	+80 -20	+100 -0	More than 10μF -10 ~ +50 Less than 4.7μF -10 ~ +75

(Less than 10pF)

Gode	B	C	D	F	G
(pF)	±0.1	±0.25	±0.5	±1	±2

Voltage rating

2nd word	A	B	C	D	E	F	G	H	J	K	V	
1st word	0	1.0	1.25	1.6	2.0	2.5	3.15	4.0	5.0	6.3	8.0	-
1	10	12.5	16	20	25	31.5	40	50	63	80	35	-
2	100	125	160	200	250	315	400	500	630	800	-	-
3	1000	1250	1600	2000	2500	3150	4000	5000	6300	8000	-	-

Chip capacitors

(EX) C C 7 3 F S L 1 H 0 0 0 J
 1 2 3 4 5 6 7

(Chip)(CH,RH<UJ,SL)

(EX) C K 7 3 F F 1 H 0 0 0 Z
 1 2 3 4 5 6 7

(Chip)(B,F)

Refer to the table above.

- 1 = Type
- 2 = Shape
- 3 = Dimension
- 4 = Temp. coefficient
- 5 = Voltage rating
- 6 = Value
- 7 = Tolerance

Dimension (Chip capacitors)

Dimension code	L	W	T
Empty	5.6 ± 0.5	5.0 ± 0.5	Less than 2.0
A	4.5 ± 0.5	3.2 ± 0.4	Less than 2.0
B	4.5 ± 0.5	2.0 ± 0.3	Less than 2.0
C	4.5 ± 0.5	1.25 ± 0.2	Less than 1.25
D	3.2 ± 0.4	2.5 ± 0.3	Less than 1.5
E	3.0 ± 0.2	1.6 ± 0.2	Less than 1.25
F	2.0 ± 0.3	1.25 ± 0.2	Less than 1.25
G	1.6 ± 0.2	0.8 ± 0.2	Less than 1.0
H	1.0 ± 0.05	0.5 ± 0.05	0.5 ± 0.05

RESISTORS

Chip resistor (Carbon)

(EX) R K 7 3 E B 2 B 0 0 0 J
 1 2 3 4 5 6 7

(Chip)(B,F)

Carbon resistor (Nomal type)

(EX) R D 1 4 B B 2 C 0 0 0 J
 1 2 3 4 5 6 7

- 1 = Type
- 2 = Shape
- 3 = Dimension
- 4 = Temp. coefficient
- 5 = Rating wattage
- 6 = Value
- 7 = Tolerance

Dimension

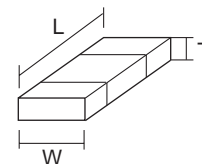

Dimension (Chip resistor)

Dimension code	L	W	T
E	3.2 ± 0.2	1.6 ± 0.2	1.0
F	2.0 ± 0.3	1.25 ± 0.2	1.0
G	1.6 ± 0.2	0.8 ± 0.2	0.5 ± 0.1
H	1.0 ± 0.05	0.5 ± 0.05	0.35 ± 0.05

Rating wattage

Code	Wattage	Code	Wattage	Code	Wattage
1J	1/16W	2C	1/16W	3A	1W
2A	1/10W	2E	1/4W	3D	2W
2B	1/8W	2H	1/2W		

PARTS LIST

* New Parts. Δ indicates safety critical components.
 Parts without **Parts No.** are not supplied.
 Les articles non mentionnes dans le **Parts No.** ne sont pas fournis.
 Teile ohne **Parts No.** werden nicht geliefert.

TK-8102

TX-RX UNIT (X57-6300-XX)

Ref. No.	Address	New parts	Parts No.	Description	Destination	Ref. No.	Address	New parts	Parts No.	Description	Destination
TK-8102											
1	1B		A01-2178-02	CABINET		J1			E08-0877-05	MODULAR JACK	
2	3B		A10-4047-01	CHASSIS		CP3,4			RK75GB1J392J	CHIP-COM 3.9K J 1/16W	
3	3A		A62-0942-03	PANEL ASSY		R1-6			RK73GB1J102J	CHIP R 1.0K J 1/16W	
4	3A		B10-2668-03	FRONT GLASS		R7-15			RK73FB2A272J	CHIP R 2.7K J 1/10W	
5	2C		B62-1389-00	INSTRUCTION MANUAL		Q1-8			KRC102S	DIGITAL TRANSISTOR	
6	3B	*	B72-1946-14	MODEL NAME PLATE	M	Q9			KRA225S	DIGITAL TRANSISTOR	
6	3B	*	B72-1947-04	MODEL NAME PLATE	M2	Q10			KRC102S	DIGITAL TRANSISTOR	
6	3B	*	B72-1948-04	MODEL NAME PLATE	M3	TX-RX UNIT (X57-6300-XX) -20:M, -21:M2, -22:M3					
7	3B		E04-0167-05	RF COAXIAL PECEPTACLE(M)		C12			CK73GB1H102K	CHIP C 1000PF K	
8	1C		E30-3339-05	DC CORD ACCESSORY		C14			C92-0560-05	CHIP-TAN 10UF 6.3VW	
9	2B		E30-3448-05	DC CORD(RADIO)		C22			CK73GB1H102K	CHIP C 1000PF K	
10	2A		E37-0961-05	FLAT CABLE		C24			CK73GB1H103K	CHIP C 0.010UF K	
11	3A		E37-0962-05	SPEAKER CABLE		C25			CC73GCH1H220J	CHIP C 22PF J	
12	2B		F10-2405-12	SHIELDING COVER(UPPER)		C26			CK73GB1C104K	CHIP C 0.10UF K	
13	2B		F10-2414-03	SHIELDING PLATE(POWER MODULE)		C27			C92-0560-05	CHIP-TAN 10UF 6.3VW	
			F51-0016-05	FUSE(6*30) ACCESSORY		C28			CK73GB1H471K	CHIP C 470PF K	
14	3B		G02-0887-03	EARTH SPRING(TX/RX)		C29,30			CK73GB1C104K	CHIP C 0.10UF K	
15	2B		G10-0792-14	FIBROUS SHEET(POWER MODULE)	M2,M3	C31,32			C92-0507-05	CHIP-TAN 4.7UF 6.3VW	
16	2A	*	G11-4065-04	SHEET(KEY TOP)		C34			CK73GB1C104K	CHIP C 0.10UF K	
17	3B		G13-1468-04	CUSHION(DC CORD)		C35			C92-0560-05	CHIP-TAN 10UF 6.3VW	
18	3A		G13-1836-04	CUSHION(SPEAKER)		C36			CK73GB1H103K	CHIP C 0.010UF K	
19	1B		G53-1524-02	PACKING		C37			CK73GB1C104K	CHIP C 0.10UF K	
20	3B		G53-1525-03	PACKING(PANEL)		C40			C92-0514-05	CHIP-TAN 2.2UF 10VW	
21	2B		G53-1542-03	PACKING(PHONE JACK)		C42			CK73GB1H102K	CHIP C 1000PF K	
22	1C		H02-0617-02	INNER PACKING CASE		C44			CK73GB1C273K	CHIP C 0.027UF K	
23	3C		H10-6636-03	POLYSTYRENE FOAMED FIXTURE		C45			CK73GB1H102K	CHIP C 1000PF K	
24	2D		H10-6639-03	POLYSTYRENE FOAMED FIXTURE		C48,49			CK73GB1H471K	CHIP C 470PF K	
25	1C		H25-0103-04	PROTECTION BAG		C50			CK73GB1C223K	CHIP C 0.022UF K	
26	2D		H25-2320-04	PROTECTION BAG		C51			CK73GB1C104K	CHIP C 0.10UF K	
27	3D	*	H52-1699-12	ITEM CARTON CASE		C52			C92-0507-05	CHIP-TAN 4.7UF 6.3VW	
28	1D		J29-0662-03	BRACKET ACCESSORY		C53			CK73GB1C104K	CHIP C 0.10UF K	
29	2A		K29-9065-01	KEY TOP		C54			C92-0560-05	CHIP-TAN 10UF 6.3VW	
A	2B		N67-3008-46	PAN HEAD SEMS SCREW		C55			CK73GB1H471K	CHIP C 470PF K	
B	2B		N87-2606-46	BRAZIER HEAD TAPTITE SCREW		C56			C92-0555-05	CHIP-TAN 0.047UF 35VW	
C	2B		N87-2614-46	BRAZIER HEAD TAPTITE SCREW		C58			CK73GB1H122K	CHIP C 1200PF K	
D	1C		N99-0395-05	SCREW SET ACCESSORY		C59			CK73GB1E103K	CHIP C 0.010UF K	
SP	3A		T07-0727-05	SPEAKER		C60			C92-0543-05	CHIP-TAN 3.3UF 10VW	
DISPLAY UNIT (X54-3340-20)											
D1-4			B30-2238-05	LED(Y)		C61			CK73GB1H821K	CHIP C 820PF K	
D5-10			B30-2239-05	LED(SY)		C62			CK73GB1H332K	CHIP C 3300PF K	
D11			B30-2237-05	LED(YG)		C63			CK73GB1H472K	CHIP C 4700PF K	
D12			B30-2240-05	LED(SR)		C64			C92-0560-05	CHIP-TAN 10UF 6.3VW	
C4			CK73GB1H103K	CHIP C 0.010UF K		C65			C92-0001-05	CHIP-C 0.1UF 35VW	
C8-17			CK73GB1H103K	CHIP C 0.010UF K		C66			CC73GCH1H151J	CHIP C 150PF J	
C18			CC73GCH1H101J	CHIP C 100PF J		C69			CK73GB1H471K	CHIP C 470PF K	
C19			CK73GB1H102K	CHIP C 1000PF K		C71			CK73GB1C104K	CHIP C 0.10UF K	
CN1			E40-6170-05	FLAT CABLE CONNECTOR		C73			CC73GCH1H040B	CHIP C 4.0PF B	M2
						C73			CC73GCH1H070B	CHIP C 7.0PF B	M3
						C73,74			CC73GCH1H080B	CHIP C 8.0PF B	M
						C74			CC73GCH1H050B	CHIP C 5.0PF B	M2
						C74			CC73GCH1H080B	CHIP C 8.0PF B	M3
						C75			CC73GCH1H030B	CHIP C 3.0PF B	M2
						C75			CC73GCH1H060B	CHIP C 6.0PF B	M,M3

PARTS LIST

TX-RX UNIT (X57-6300-XX)

Ref. No.	Address	New parts	Parts No.	Description	Destination	Ref. No.	Address	New parts	Parts No.	Description	Destination
C77			CC73GCH1H0R5B	CHIP C 0.5PF B		C145			CC73GCH1H060B	CHIP C 6.0PF B	
C78			CC73GCH1H040B	CHIP C 4.0PF B	M2	C146			CK73GB1H471K	CHIP C 470PF K	
C78			CC73GCH1H050B	CHIP C 5.0PF B	M3	C147			CK73GB1E223K	CHIP C 0.022UF K	
C78			CC73GCH1H060B	CHIP C 6.0PF B	M	C150			CC73GCH1H180J	CHIP C 18PF J	
C79			CK73GB1H471K	CHIP C 470PF K		C154			CK73GB1H471K	CHIP C 470PF K	
C80			CK73GB1H103K	CHIP C 0.010UF K		C155			CK73GB1H103K	CHIP C 0.010UF K	
C81			CC73GCH1H271J	CHIP C 270PF J		C156			CC73GCH1H020B	CHIP C 2.0PF B	
C82			CK73GB1H471K	CHIP C 470PF K		C157			CK73GB1H471K	CHIP C 470PF K	
C84			CK73GB1C104K	CHIP C 0.10UF K		C160			CK73FB1C334K	CHIP C 0.33UF K	
C85			CC73GCH1H010B	CHIP C 1.0PF B	M	C162			CC73GCH1H050B	CHIP C 5.0PF B	
C85			CC73GCH1H020B	CHIP C 2.0PF B	M2	C163			CC73GCH1H120J	CHIP C 12PF J	
C85,86			CC73GCH1H020B	CHIP C 2.0PF B	M3	C165			CK73GB1H103K	CHIP C 0.010UF K	
C86			CC73GCH1H1R5B	CHIP C 1.5PF B	M,M2	C166			CC73GCH1H1R5B	CHIP C 1.5PF B	M,M3
C87			CC73GCH1H560J	CHIP C 56PF J		C168			CK73GB1H103K	CHIP C 0.010UF K	
C88			CK73GB1C104K	CHIP C 0.10UF K		C169			CK73GB1H471K	CHIP C 470PF K	
C89			CC73GCH1H270J	CHIP C 27PF J		C170			CC73GCH1H050B	CHIP C 5.0PF B	
C90			CK73GB1H471K	CHIP C 470PF K		C171			CC73GCH1H080B	CHIP C 8.0PF B	
C94			CC73GCH1H101J	CHIP C 100PF J		C173			CK73GB1C104K	CHIP C 0.10UF K	
C95			CC73GCH1H020B	CHIP C 2.0PF B	M2,M3	C174			CC73GCH1H050B	CHIP C 5.0PF B	
C95			CC73GCH1H050B	CHIP C 5.0PF B	M	C176			CK73GB1H471K	CHIP C 470PF K	
C97			CC73GCH1H020B	CHIP C 2.0PF B	M2,M3	C177			CC73GCH1H070B	CHIP C 7.0PF B	
C97			CC73GCH1H040B	CHIP C 4.0PF B	M	C178			CK73GB1C104K	CHIP C 0.10UF K	
C99			CC73GCH1H050B	CHIP C 5.0PF B	M	C179			CK73GB1H471K	CHIP C 470PF K	
C99,100			CC73GCH1H030B	CHIP C 3.0PF B	M2,M3	C180			CK73GB1H103J	CHIP C 0.010UF J	
C100			CC73GCH1H040B	CHIP C 4.0PF B	M	C182			CK73GB1C104K	CHIP C 0.10UF K	
C101			CK73GB1H471K	CHIP C 470PF K		C184			CK73GB1H471K	CHIP C 470PF K	
C102			CK73GB1C104K	CHIP C 0.10UF K		C185			CK73GB1H103J	CHIP C 0.010UF J	
C103			C92-0568-05	CHIP-TAN 22UF 10WV		C186			CC73GCH1H0R5B	CHIP C 0.5PF B	
C104,105			CC73GCH1H0R5B	CHIP C 0.5PF B		C187,188			CK73GB1H471K	CHIP C 470PF K	
C106			CC73GCH1H180J	CHIP C 18PF J		C191			CK73GB1C473K	CHIP C 0.047UF K	
C107			CC73GCH1H060B	CHIP C 6.0PF B		C192,193			CK73GB1H103J	CHIP C 0.010UF J	
C108,109			CK73GB1H471K	CHIP C 470PF K		C194			CK73GB1H471K	CHIP C 470PF K	
C110			CC73GCH1H060B	CHIP C 6.0PF B		C196			CK73GB1C333K	CHIP C 0.033UF K	
C111,112			CC73GCH1H121J	CHIP C 120PF J	M3	C197			CK73GB1H471K	CHIP C 470PF K	
C111,112			CC73GCH1H221J	CHIP C 220PF J	M,M2	C198			CK73GB1C333K	CHIP C 0.033UF K	
C113			CK73GB1H471K	CHIP C 470PF K		C199			CC73GCH1H080B	CHIP C 8.0PF B	M
C114			CK73GB1C104K	CHIP C 0.10UF K		C199,200			CC73GCH1H080B	CHIP C 8.0PF B	M2,M3
C115			CC73GCH1H060B	CHIP C 6.0PF B		C200			CC73GCH1H090B	CHIP C 9.0PF B	M
C116,117			CK73GB1C104K	CHIP C 0.10UF K		C201			CK73GB1H471K	CHIP C 470PF K	
C118			CC73GCH1H020B	CHIP C 2.0PF B		C202			CC73GCH1H150J	CHIP C 15PF J	
C119			CK73GB1H103K	CHIP C 0.010UF K		C204			CK73GB1H471K	CHIP C 470PF K	
C120			CK73GB1H102K	CHIP C 1000PF K	M3	C207			CC73GCH1H221J	CHIP C 220PF J	
C120			CK73GB1H472K	CHIP C 4700PF K	M,M2	C208			CK73GB1H103K	CHIP C 0.010UF K	
C122			CC73GCH1H040B	CHIP C 4.0PF B		C209,210			CK73GB1H471K	CHIP C 470PF K	
C123			C92-0662-05	CHIP-TAN 15UF 6.3WV		C211			CK73GB1E183K	CHIP C 0.018UF K	
C125,126			CK73GB1H471K	CHIP C 470PF K		C212			CK73GB1H822K	CHIP C 8200PF K	
C127			CK73GB1H103K	CHIP C 0.010UF K		C213			CK73GB1H471K	CHIP C 470PF K	
C128			CK73GB1H102K	CHIP C 1000PF K		C214			CK73GB1C683K	CHIP C 0.068UF K	
C129			CK73GB1C104K	CHIP C 0.10UF K		C216			CC73GCH1H070B	CHIP C 7.0PF B	
C135			CK73GB1H103K	CHIP C 0.010UF K		C217			CK73FB1A105K	CHIP C 1.0UF K	
C136			CK73GB1H102K	CHIP C 1000PF K		C218			CK73GB1C104K	CHIP C 0.10UF K	
C138			CC73GCH1H330J	CHIP C 33PF J		C220			CK73GB1C473K	CHIP C 0.047UF K	
C141			CK73GB1H471K	CHIP C 470PF K		C221			CK73GB1H471K	CHIP C 470PF K	
C142			CK73GB1E223K	CHIP C 0.022UF K		C222			CK73GB1E123K	CHIP C 0.012UF K	
C143			CK73GB1H102K	CHIP C 1000PF K		C223			C92-0507-05	CHIP-TAN 4.7UF 6.3WV	
C144			CK73GB1H392K	CHIP C 3900PF K		C225			CK73GB1H222K	CHIP C 2200PF K	

PARTS LIST

TX-RX UNIT (X57-6300-XX)

Ref. No.	Address	New parts	Parts No.	Description	Destination	Ref. No.	Address	New parts	Parts No.	Description	Destination
C226			CK73GB1C683K	CHIP C 0.068UF K		C316			C92-0516-05	CHIP-TAN 4.7UF 16WV	
C228			CK73GB1H471K	CHIP C 470PF K		C318			CK73GB1H471K	CHIP C 470PF K	
C230			CK73GB1H471K	CHIP C 470PF K		C320			C92-0722-05	ELECTRO 470UF 16WV	
C232			CK73GB1H471K	CHIP C 470PF K		C323			C93-0553-05	CHIP C 3.0PF C	M2
C233			C92-0719-05	ELECTRO 47UF 25WV		C323			C93-0554-05	CHIP C 4.0PF C	M
C236			CC73GCH1H060B	CHIP C 6.0PF B	M2	C323			C93-0556-05	CHIP C 6.0PF D	M3
C236			CC73GCH1H070B	CHIP C 7.0PF B	M,M3	C324			CK73GB1H471K	CHIP C 470PF K	
C237			CK73GB1C104K	CHIP C 0.10UF K		C326			CK73GB1H471K	CHIP C 470PF K	
C239			CK73GB1H471K	CHIP C 470PF K		C327			CK73GB1H102K	CHIP C 1000PF K	
C242			CK73GB1H471K	CHIP C 470PF K		C328			CK73GB1H471K	CHIP C 470PF K	
C243			CK73GB1C104K	CHIP C 0.10UF K		C329			CK73GB1H103K	CHIP C 0.010UF K	
C246			C92-0719-05	ELECTRO 47UF 25WV		C330-332			CC73GCH1H101J	CHIP C 100PF J	
C247			CC73GCH1H050B	CHIP C 5.0PF B	M2	C333			CK73GB1H471K	CHIP C 470PF K	
C247			CC73GCH1H070B	CHIP C 7.0PF B	M,M3	C334			CC73GCH1H180J	CHIP C 18PF J	
C251,252			CK73GB1H471K	CHIP C 470PF K		C335,336			CK73GB1C104K	CHIP C 0.10UF K	
C254			C92-0004-05	CHIP-TAN 1.0UF 16WV		C337			C92-0507-05	CHIP-TAN 4.7UF 6.3WV	
C255			CC73GCH1H0R5B	CHIP C 0.5PF B		C338			CK73GB1C104K	CHIP C 0.10UF K	
C256			CK73GB1C104K	CHIP C 0.10UF K		C340			C92-0560-05	CHIP-TAN 10UF 6.3WV	
C262			C92-0568-05	CHIP-TAN 22UF 10WV		C341			CK73GB1H471K	CHIP C 470PF K	
C264			CK73GB1H471K	CHIP C 470PF K		C342			C92-0507-05	CHIP-TAN 4.7UF 6.3WV	
C265			C92-0568-05	CHIP-TAN 22UF 10WV		C344-350			CK73GB1H471K	CHIP C 470PF K	
C266			CC73GCH1H030B	CHIP C 3.0PF B	M2	C351			CK73GB1H102K	CHIP C 1000PF K	
C266			CC73GCH1H060B	CHIP C 6.0PF B	M,M3	C352,353			CK73GB1H471K	CHIP C 470PF K	
C268			C92-0568-05	CHIP-TAN 22UF 10WV		C355			CK73GB1C104K	CHIP C 0.10UF K	
C269			CK73GB1H103K	CHIP C 0.010UF K		C356			CK73GB1H103K	CHIP C 0.010UF K	
C271			CK73GB1H103K	CHIP C 0.010UF K		C358-361			CK73GB1H471K	CHIP C 470PF K	
C273			CC73GCH1H0R5B	CHIP C 0.5PF B		C362			CK73GB1C104K	CHIP C 0.10UF K	
C274			CK73GB1H103K	CHIP C 0.010UF K		C363			CC73GCH1H050B	CHIP C 5.0PF B	M2
C275			CK73GB1C104K	CHIP C 0.10UF K		C363			CC73GCH1H080B	CHIP C 8.0PF B	M,M3
C277			CK73FB1A105K	CHIP C 1.0UF K		C364,365			CK73GB1H471K	CHIP C 470PF K	
C279			CK73GB1H471K	CHIP C 470PF K		C366			CC73GCH1H070B	CHIP C 7.0PF B	
C280			C92-0633-05	CHIP-TAN 22UF 10WV		C367			CK73GB1H471K	CHIP C 470PF K	
C283			CK73GB1H471K	CHIP C 470PF K		C369			CK73GB1H471K	CHIP C 470PF K	
C284			CK73FB1C224K	CHIP C 0.22UF K		C371,372			CK73GB1H471K	CHIP C 470PF K	
C286			CK73GB1C104K	CHIP C 0.10UF K		C374			C92-0507-05	CHIP-TAN 4.7UF 6.3WV	
C288			C92-0721-05	ELECTRO 330UF 25WV		C375			CK73GB1C104K	CHIP C 0.10UF K	
C289			C93-0603-05	CHIP C 1000PF K		C376			CK73GB1H471K	CHIP C 470PF K	
C290			CK73GB1H471K	CHIP C 470PF K		C377			C92-0004-05	CHIP-TAN 1.0UF 16WV	
C291			CC73GCH1H0R5B	CHIP C 0.5PF B		C378			CK73GB1H471K	CHIP C 470PF K	
C292			CC73GCH1H020B	CHIP C 2.0PF B		C379			CK73GB1C104K	CHIP C 0.10UF K	
C294,295			CK73GB1H471K	CHIP C 470PF K		C511			CK73GB1H471K	CHIP C 470PF K	
C296			C93-0550-05	CHIP C 1.0PF C	M2	C512,513			CC73GCH1H101J	CHIP C 100PF J	
C296			C93-0552-05	CHIP C 2.0PF C	M,M3	C514			C92-0004-05	CHIP-TAN 1.0UF 16WV	M,M2
C298,299			CK73GB1H471K	CHIP C 470PF K		C514			C92-0514-05	CHIP-TAN 2.2UF 10WV	M3
C301			C93-0550-05	CHIP C 1.0PF C		C515			CK73GB1H471K	CHIP C 470PF K	
C302			C92-0040-05	CHIP-ELE 47UF 16WV		C518			C92-0507-05	CHIP-TAN 4.7UF 6.3WV	
C303,304			CK73GB1H471K	CHIP C 470PF K		C520			CK73GB1H102K	CHIP C 1000PF K	
C305			C93-0554-05	CHIP C 4.0PF C	M2	C521			CK73GB1H392K	CHIP C 3900PF K	
C305			C93-0556-05	CHIP C 6.0PF D	M	C522			CK73FB1A105K	CHIP C 1.0UF K	
C305			C93-0557-05	CHIP C 7.0PF D	M3	C523			C93-0550-05	CHIP C 1.0PF C	
C307			CK73GB1H471K	CHIP C 470PF K		C524			CK73GB1H102K	CHIP C 1000PF K	
C308			C92-0560-05	CHIP-TAN 10UF 6.3WV		C525			C93-0550-05	CHIP C 1.0PF C	M,M2
C310			CK73GB1H103K	CHIP C 0.010UF K		C525			C93-0552-05	CHIP C 2.0PF C	M3
C312			CC73GCH1H0R5B	CHIP C 0.5PF B		C526			CK73GB1H102K	CHIP C 1000PF K	
C313			CC73GCH1H020B	CHIP C 2.0PF B		TC1			C05-0245-05	CERAMIC TRIMMER CAP(10PF)	M3
C314			CK73GB1C104K	CHIP C 0.10UF K		TC1,2			C05-0245-05	CERAMIC TRIMMER CAP(10PF)	M,M2

PARTS LIST

TX-RX UNIT (X57-6300-XX)

Ref. No.	Address	New parts	Parts No.	Description	Destination	Ref. No.	Address	New parts	Parts No.	Description	Destination
TC2,3			C05-0399-05	CERAMIC TRIMMER CAP(6PF)	M3	L38			L34-4604-05	AIR-CORE COIL	M,M2
TC3			C05-0399-05	CERAMIC TRIMMER CAP(6PF)	M,M2	L38			L34-4605-05	AIR-CORE COIL	M3
TC5			C05-0399-05	CERAMIC TRIMMER CAP(6PF)	M,M2	L40			L34-4478-05	AIR-CORE COIL	
TC5			C05-0400-05	CERAMIC TRIMMER CAP(3PF)	M3	L42			L34-1185-05	AIR-CORE COIL	
						L43,44			L34-1039-05	AIR-CORE COIL	
CN1			E40-5651-05	FLAT CABLE CONNECTOR							
CN5			E40-3246-05	PIN ASSY		L45			L34-4478-05	AIR-CORE COIL	
CN6			E23-0486-05	TERMINAL		L46			L41-2775-06	SMALL FIXED INDUCTOR	
J1			E11-0425-05	3.5D PHONE JACK(3P)		L48,49			L34-4604-05	AIR-CORE COIL	
J2			E37-0804-05	PROCESSED LEAD WIRE	M	L50			L40-3975-92	SMALL FIXED INDUCTOR(39NH)	
						L51			L40-1875-92	SMALL FIXED INDUCTOR(18NH)	M,M2
CF1			L72-0993-05	CERAMIC FILTER							
CF2			L72-0994-05	CERAMIC FILTER	M	L51			L40-2275-92	SMALL FIXED INDUCTOR(22NH)	M3
CF2		*	L72-0999-05	CERAMIC FILTER	M2,M3	L54,55			L92-0179-05	FERRITE CHIP	
L1			L92-0140-05	FERRITE CHIP		X1	*		L77-1868-15	TCXO (16.8MHZ)	
L2		*	L41-1005-08	SMALL FIXED INDUCTOR		X2			L77-1867-05	CRYSTAL RESONATOR(7.159MHZ)	
						XF1			L71-0591-05	MCF (49.95MHZ)	
L3			L92-0138-05	FERRITE CHIP							
L4			L92-0140-05	FERRITE CHIP		R1			RK73GB1J332J	CHIP R 3.3K J 1/16W	
L5,6			L40-2702-86	SMALL FIXED INDUCTOR(27UH)	M	R2			RK73GB1J102J	CHIP R 1.0K J 1/16W	
L5,6			L40-2785-92	SMALL FIXED INDUCTOR(270NH)	M2,M3	R3			R92-1252-05	CHIP R 0 OHM	
L7			L92-0140-05	FERRITE CHIP		R4,5			RK73GB1J101J	CHIP R 100 J 1/16W	
						R6,7			R92-1252-05	CHIP R 0 OHM	
L8			L40-2702-86	SMALL FIXED INDUCTOR(27UH)	M						
L8			L40-2785-92	SMALL FIXED INDUCTOR(270NH)	M2,M3	R10,11			RK73GB1J102J	CHIP R 1.0K J 1/16W	
L9			L40-3378-67	SMALL FIXED INDUCTOR(33NH)	M	R12			RK73GB1J152J	CHIP R 1.5K J 1/16W	
L9			L40-3978-67	SMALL FIXED INDUCTOR(39NH)	M2	R13			RK73GB1J102J	CHIP R 1.0K J 1/16W	
L9			L40-5678-67	SMALL FIXED INDUCTOR(56NH)	M3	R15			RK73GB1J100J	CHIP R 10 J 1/16W	
						R18			RK73GB1J913J	CHIP R 91K J 1/16W	
L10			L40-2702-86	SMALL FIXED INDUCTOR(27UH)	M						
L10			L40-2785-92	SMALL FIXED INDUCTOR(270NH)	M2,M3	R19			RK73GB1J683J	CHIP R 68K J 1/16W	
L11			L40-2778-67	SMALL FIXED INDUCTOR(27NH)	M	R20			RK73GB1J104J	CHIP R 100K J 1/16W	
L11			L40-3378-67	SMALL FIXED INDUCTOR(33NH)	M2	R21			RK73GB1J152J	CHIP R 1.5K J 1/16W	
L11			L40-4778-67	SMALL FIXED INDUCTOR(47NH)	M3	R22			RK73GB1J122J	CHIP R 1.2K J 1/16W	
						R23			RK73GB1J102J	CHIP R 1.0K J 1/16W	
L12			L40-3381-86	SMALL FIXED INDUCTOR(0.33UH)							
L13			L40-1885-92	SMALL FIXED INDUCTOR(180NH)	M2,M3	R24			RK73GB1J754J	CHIP R 750K J 1/16W	
L13			L40-2702-86	SMALL FIXED INDUCTOR(27UH)	M	R26,27			RK73GH1J153D	CHIP R 15K D 1/16W	
L14			L40-3381-86	SMALL FIXED INDUCTOR(0.33UH)		R28			R92-1252-05	CHIP R 0 OHM	
L15			L40-1885-92	SMALL FIXED INDUCTOR(180NH)	M2	R30			RK73GB1J152J	CHIP R 1.5K J 1/16W	
						R31			RK73GB1J244J	CHIP R 240K J 1/16W	
L15			L40-2702-86	SMALL FIXED INDUCTOR(27UH)	M						
L15			L40-2785-92	SMALL FIXED INDUCTOR(270NH)	M3	R32			R92-1252-05	CHIP R 0 OHM	
L16			L92-0140-05	FERRITE CHIP		R33			RK73GB1J102J	CHIP R 1.0K J 1/16W	
L17		*	L41-3385-08	SMALL FIXED INDUCTOR		R34			RK73GB1J123J	CHIP R 12K J 1/16W	
L18			L92-0140-05	FERRITE CHIP		R36			RK73GB1J471J	CHIP R 470 J 1/16W	
						R37-39			RK73GB1J103J	CHIP R 10K J 1/16W	
L19,20			L40-2702-86	SMALL FIXED INDUCTOR(27UH)	M						
L19,20			L40-2785-92	SMALL FIXED INDUCTOR(270NH)	M2,M3	R40			RK73GB1J224J	CHIP R 220K J 1/16W	
L21			L41-2775-06	SMALL FIXED INDUCTOR		R41,42			RK73GB1J183J	CHIP R 18K J 1/16W	
L22			L34-4554-05	COIL		R43			RK73GB1J223J	CHIP R 22K J 1/16W	
L23			L92-0140-05	FERRITE CHIP		R44			R92-1252-05	CHIP R 0 OHM	
						R45			RK73GB1J334J	CHIP R 330K J 1/16W	
L24			L41-2775-06	SMALL FIXED INDUCTOR							
L26,27			L40-4785-85	SMALL FIXED INDUCTOR(0.47UH)		R46			RK73GB1J102J	CHIP R 1.0K J 1/16W	
L30			L34-4603-05	AIR-CORE COIL	M2	R47			RK73GB1J473J	CHIP R 47K J 1/16W	
L30			L34-4604-05	AIR-CORE COIL	M	R48			RK73GB1J683J	CHIP R 68K J 1/16W	
L30			L34-4605-05	AIR-CORE COIL	M3	R49			RK73GB1J823J	CHIP R 82K J 1/16W	
						R50			RK73GB1J153J	CHIP R 15K J 1/16W	
L31			L41-1875-08	SMALL FIXED INDUCTOR							
L32			L34-4604-05	AIR-CORE COIL	M,M2	R51			RK73GB1J102J	CHIP R 1.0K J 1/16W	
L32			L34-4605-05	AIR-CORE COIL	M3	R52			RK73GB1J683J	CHIP R 68K J 1/16W	
L33			L41-2275-08	SMALL FIXED INDUCTOR		R53			RK73GB1J823J	CHIP R 82K J 1/16W	
L36			L34-4603-05	AIR-CORE COIL	M2	R54			RK73GB1J103J	CHIP R 10K J 1/16W	
						R55			RK73GB1J222J	CHIP R 2.2K J 1/16W	
L36			L34-4604-05	AIR-CORE COIL	M						
L36			L34-4605-05	AIR-CORE COIL	M3	R56			RK73GB1J152J	CHIP R 1.5K J 1/16W	

PARTS LIST

TX-RX UNIT (X57-6300-XX)

Ref. No.	Address	New parts	Parts No.	Description	Destination	Ref. No.	Address	New parts	Parts No.	Description	Destination
R57			RK73GB1J683J	CHIP R 68K J 1/16W		R142-144			RK73GB1J102J	CHIP R 1.0K J 1/16W	
R58			RK73GB1J473J	CHIP R 47K J 1/16W		R145			R92-1252-05	CHIP R 0 OHM	
R59			RK73GB1J223J	CHIP R 22K J 1/16W		R146			RK73GB1J334J	CHIP R 330K J 1/16W	
R60			RK73GB1J103J	CHIP R 10K J 1/16W		R147			RK73GB1J124J	CHIP R 120K J 1/16W	
R61			RK73GB1J473J	CHIP R 47K J 1/16W		R149			RK73GB1J104J	CHIP R 100K J 1/16W	
R62,63			RK73GB1J104J	CHIP R 100K J 1/16W		R150			RK73GB1J102J	CHIP R 1.0K J 1/16W	
R64			RK73GB1J154J	CHIP R 150K J 1/16W		R151			RK73GB1J103J	CHIP R 10K J 1/16W	
R67			RK73GB1J223J	CHIP R 22K J 1/16W		R152			RK73GB1J473J	CHIP R 47K J 1/16W	
R70			RK73GB1J473J	CHIP R 47K J 1/16W		R153			RK73GB1J561J	CHIP R 560 J 1/16W	
R72			RK73GB1J154J	CHIP R 150K J 1/16W		R154			RK73GB1J471J	CHIP R 470 J 1/16W	
R73,74			RK73GB1J103J	CHIP R 10K J 1/16W		R155			RK73GB1J472J	CHIP R 4.7K J 1/16W	
R76			RK73GB1J101J	CHIP R 100 J 1/16W		R156			RK73GB1J101J	CHIP R 100 J 1/16W	
R77,78			RK73GB1J103J	CHIP R 10K J 1/16W		R158			RK73GB1J102J	CHIP R 1.0K J 1/16W	
R80-85			RK73GB1J102J	CHIP R 1.0K J 1/16W		R159			RK73GB1J101J	CHIP R 100 J 1/16W	
R86			RK73GB1J101J	CHIP R 100 J 1/16W		R160			RK73GB1J102J	CHIP R 1.0K J 1/16W	
R87			RK73GB1J223J	CHIP R 22K J 1/16W		R161			RK73GB1J333J	CHIP R 33K J 1/16W	
R88			RK73GB1J101J	CHIP R 100 J 1/16W		R162			RK73GB1J102J	CHIP R 1.0K J 1/16W	
R89			RK73GB1J104J	CHIP R 100K J 1/16W		R163			RK73GB1J561J	CHIP R 560 J 1/16W	
R94			RK73GB1J472J	CHIP R 4.7K J 1/16W		R164			RK73GB1J473J	CHIP R 47K J 1/16W	
R97			RK73GB1J102J	CHIP R 1.0K J 1/16W		R165			RK73GB1J333J	CHIP R 33K J 1/16W	
R98			RK73GB1J221J	CHIP R 220 J 1/16W	M	R166			RK73GB1J102J	CHIP R 1.0K J 1/16W	
R98			RK73GB1J271J	CHIP R 270 J 1/16W	M2	R167			RK73GB1J470J	CHIP R 47 J 1/16W	
R98			RK73GB1J331J	CHIP R 330 J 1/16W	M3	R168			RK73GB1J333J	CHIP R 33K J 1/16W	
R99			RK73GB1J151J	CHIP R 150 J 1/16W	M	R169			RK73GB1J222J	CHIP R 2.2K J 1/16W	
R99			RK73GB1J221J	CHIP R 220 J 1/16W	M2	R172			RK73GB1J102J	CHIP R 1.0K J 1/16W	
R99			RK73GB1J271J	CHIP R 270 J 1/16W	M3	R173			RK73GB1J104J	CHIP R 100K J 1/16W	
R100			RK73GB1J102J	CHIP R 1.0K J 1/16W		R174			RK73GB1J220J	CHIP R 22 J 1/16W	
R101			RK73GB1J124J	CHIP R 120K J 1/16W		R175			RK73GB1J181J	CHIP R 180 J 1/16W	
R102			RK73GB1J223J	CHIP R 22K J 1/16W		R176			RK73GB1J823J	CHIP R 82K J 1/16W	
R103			RK73GB1J182J	CHIP R 1.8K J 1/16W	M,M2	R177			RK73GB1J102J	CHIP R 1.0K J 1/16W	
R103			RK73GB1J183J	CHIP R 18K J 1/16W	M2	R178			RK73GB1J152J	CHIP R 1.5K J 1/16W	
R104			R92-1252-05	CHIP R 0 OHM		R179			RK73GB1J154J	CHIP R 150K J 1/16W	
R106			RK73GB1J123J	CHIP R 12K J 1/16W	M3	R181			RK73GB1J102J	CHIP R 1.0K J 1/16W	
R106			RK73GB1J472J	CHIP R 4.7K J 1/16W	M,M2	R183			RK73GB1J101J	CHIP R 100 J 1/16W	
R107			RK73GB1J101J	CHIP R 100 J 1/16W		R184			R92-1252-05	CHIP R 0 OHM	
R108			RK73GB1J224J	CHIP R 220K J 1/16W	M3	R185			RK73GB1J471J	CHIP R 470 J 1/16W	
R108			RK73GB1J274J	CHIP R 270K J 1/16W	M,M2	R186			RK73GB1J100J	CHIP R 10 J 1/16W	
R109			R92-1252-05	CHIP R 0 OHM		R188			RK73GB1J104J	CHIP R 100K J 1/16W	
R111			RK73GB1J222J	CHIP R 2.2K J 1/16W		R189			RK73GH1J124D	CHIP R 120K D 1/16W	
R113			RK73GB1J183J	CHIP R 18K J 1/16W		R190			RK73GB1J123J	CHIP R 12K J 1/16W	
R114			R92-1252-05	CHIP R 0 OHM		R191			RK73GH1J913D	CHIP R 91K D 1/16W	
R115			RK73GB1J102J	CHIP R 1.0K J 1/16W		R192			RK73GB1J562J	CHIP R 5.6K J 1/16W	
R117			RK73GB1J102J	CHIP R 1.0K J 1/16W		R194			RK73GB1J153J	CHIP R 15K J 1/16W	
R118			RK73GB1J473J	CHIP R 47K J 1/16W		R195			RK73GH1J562D	CHIP R 5.6K D 1/16W	
R119			RK73GB1J102J	CHIP R 1.0K J 1/16W		R197			RK73GB1J332J	CHIP R 3.3K J 1/16W	
R120			RK73GB1J473J	CHIP R 47K J 1/16W		R198			RK73GB1J100J	CHIP R 10 J 1/16W	
R122,123			RK73GB1J473J	CHIP R 47K J 1/16W		R201			RK73GB1J152J	CHIP R 1.5K J 1/16W	
R124			RK73GB1J472J	CHIP R 4.7K J 1/16W		R202			RK73GB1J332J	CHIP R 3.3K J 1/16W	
R127			RK73GB1J104J	CHIP R 100K J 1/16W		R203			RK73FB2A331J	CHIP R 330 J 1/10W	
R128			RK73GB1J105J	CHIP R 1.0M J 1/16W		R204			RK73GB1J104J	CHIP R 100K J 1/16W	
R130			RK73GB1J332J	CHIP R 3.3K J 1/16W		R205			RK73FB2A100J	CHIP R 10 J 1/10W	M,M3
R132			RK73GB1J471J	CHIP R 470 J 1/16W		R205			RK73FB2A330J	CHIP R 33 J 1/10W	M2
R133			RK73GB1J101J	CHIP R 100 J 1/16W		R207			RK73GB1J823J	CHIP R 82K J 1/16W	
R134			R92-1252-05	CHIP R 0 OHM		R208			RK73GB1J151J	CHIP R 150 J 1/16W	
R135-140			RK73GB1J102J	CHIP R 1.0K J 1/16W		R209			RK73GB1J394J	CHIP R 390K J 1/16W	
R141			RK73GB1J152J	CHIP R 1.5K J 1/16W		R210			RK73GB1J334J	CHIP R 330K J 1/16W	

PARTS LIST

TX-RX UNIT (X57-6300-XX)

Ref. No.	Address	New parts	Parts No.	Description	Destination	Ref. No.	Address	New parts	Parts No.	Description	Destination
R211			RK73GB1J473J	CHIP R 47K J 1/16W		R286			RK73GB1J124J	CHIP R 120K J 1/16W	
R213			R92-0685-05	CHIP R 22 J 1/2W		R287			RK73GB1J472J	CHIP R 4.7K J 1/16W	
R214			RK73GB1J562J	CHIP R 5.6K J 1/16W		R288,289			R92-1252-05	CHIP R 0 OHM	
R215			RK73GB1J104J	CHIP R 100K J 1/16W		R291			RK73GB1J124J	CHIP R 120K J 1/16W	
R216			RK73GB1J562J	CHIP R 5.6K J 1/16W		R293			RK73GB1J221J	CHIP R 220 J 1/16W	
R217			RK73GB1J474J	CHIP R 470K J 1/16W		R294			RK73GB1J681J	CHIP R 680 J 1/16W	
R218			RK73GB1J394J	CHIP R 390K J 1/16W		R295,296			R92-1252-05	CHIP R 0 OHM	
R219			RK73GB1J105J	CHIP R 1.0M J 1/16W		R298			RK73GB1J101J	CHIP R 100 J 1/16W	
R221			RK73FB2A471J	CHIP R 470 J 1/10W		R300			R92-1252-05	CHIP R 0 OHM	
R224			RK73FB2A120J	CHIP R 12 J 1/10W		R301			RK73GB1J104J	CHIP R 100K J 1/16W	
R227			RK73GB1J223J	CHIP R 22K J 1/16W		R302			RK73GB1J683J	CHIP R 68K J 1/16W	
R228			RK73GB1J184J	CHIP R 180K J 1/16W		R303			RK73GB1J334J	CHIP R 330K J 1/16W	
R229			RK73GB1J223J	CHIP R 22K J 1/16W		R304			RK73GB1J224J	CHIP R 220K J 1/16W	
R232			RK73GB1J184J	CHIP R 180K J 1/16W		R305			RK73GB1J913J	CHIP R 91K J 1/16W	
R233			RK73FB2A471J	CHIP R 470 J 1/10W		R306			RK73GB1J334J	CHIP R 330K J 1/16W	
R234			RK73GB1J153J	CHIP R 15K J 1/16W		R307			RK73GB1J333J	CHIP R 33K J 1/16W	
R236			R92-1213-05	CHIP R 100 J 1/2W		R308			R92-1252-05	CHIP R 0 OHM	
R237			RK73GB1J104J	CHIP R 100K J 1/16W		R310			RK73GB1J104J	CHIP R 100K J 1/16W	
R238			RK73GB1J153J	CHIP R 15K J 1/16W		R311			RK73GB1J101J	CHIP R 100 J 1/16W	
R239			RK73GB1J472J	CHIP R 4.7K J 1/16W		R313			RK73GB1J821J	CHIP R 820 J 1/16W	
R240			RK73FB2A222J	CHIP R 2.2K J 1/10W		R316			R92-1252-05	CHIP R 0 OHM	
R241			RK73GB1J334J	CHIP R 330K J 1/16W		R318			RK73FB2A332J	CHIP R 3.3K J 1/10W	
R242			RK73GB1J472J	CHIP R 4.7K J 1/16W		R319,320			RK73GB1J474J	CHIP R 470K J 1/16W	
R243			RK73GB1J103J	CHIP R 10K J 1/16W		R321			R92-1252-05	CHIP R 0 OHM	
R244			RK73GB1J682J	CHIP R 6.8K J 1/16W		R322			RK73GB1J683J	CHIP R 68K J 1/16W	
R245,246			RK73GB1J104J	CHIP R 100K J 1/16W		R323			R92-1252-05	CHIP R 0 OHM	
R247			RK73GB1J103J	CHIP R 10K J 1/16W		R324,325			RK73GB1J102J	CHIP R 1.0K J 1/16W	
R248			RK73GB1J473J	CHIP R 47K J 1/16W		R326			RK73GB1J333J	CHIP R 33K J 1/16W	
R249			RK73GB1J102J	CHIP R 1.0K J 1/16W		R327			RK73GB1J102J	CHIP R 1.0K J 1/16W	
R250			RK73GB1J223J	CHIP R 22K J 1/16W		R328			RK73GB1J472J	CHIP R 4.7K J 1/16W	
R251			RK73GB1J273J	CHIP R 27K J 1/16W M		R329			RK73GB1J474J	CHIP R 470K J 1/16W	
R252			RK73GB1J152J	CHIP R 1.5K J 1/16W		R330			RK73GB1J394J	CHIP R 390K J 1/16W	
R254,255			RK73GB1J473J	CHIP R 47K J 1/16W		R332			R92-0679-05	CHIP R 0 OHM	
R256			RK73GB1J104J	CHIP R 100K J 1/16W		R335			RK73GB1J472J	CHIP R 4.7K J 1/16W	
R257			R92-1261-05	CHIP R 150 J 1/2W		R336			RK73GB1J473J	CHIP R 47K J 1/16W	
R258			RK73GB1J104J	CHIP R 100K J 1/16W		D1-4			DA221	DIODE	
R260			RK73GB1J473J	CHIP R 47K J 1/16W		D6			MA2S111	DIODE	
R261			RK73GB1J123J	CHIP R 12K J 1/16W		D7			HZU5ALL	DIODE	
R262			R92-1215-05	CHIP R 470 J 1/2W		D9-12			MA2S304	VARI CAP	
R263			RK73GB1J682J	CHIP R 6.8K J 1/16W		D13			DAN222	DIODE	
R264			RK73GB1J391J	CHIP R 390 J 1/16W		D14			MA360	VARI CAP	
R265			RK73GB1J472J	CHIP R 4.7K J 1/16W		D15			DAN222	DIODE	
R266			RK73GB1J334J	CHIP R 330K J 1/16W		D16			MA2S111	DIODE	
R267			RK73GB1J223J	CHIP R 22K J 1/16W		D18			MA742	DIODE	
R268			R92-0670-05	CHIP R 0 OHM		D19			DAN235E	DIODE	
R271			RK73GB1J472J	CHIP R 4.7K J 1/16W		D21,22			HVC350B	VARI CAP	M,M3
R273			RK73GB1J102J	CHIP R 1.0K J 1/16W		D21,22			HVC355B	VARI CAP	M2
R274			RK73GB1J223J	CHIP R 22K J 1/16W		D23			DA221	DIODE	
R275			RK73GB1J333J	CHIP R 33K J 1/16W		D24			MA742	DIODE	
R276-278			RK73GB1J102J	CHIP R 1.0K J 1/16W		D25			HVC355B	VARI CAP	M3
R279			RK73GJ1J393D	CHIP R 39K D 1/16W		D25,26			HVC350B	VARI CAP	M
R280			RK73GH1J274D	CHIP R 270K D 1/16W		D25,26			HVC355B	VARI CAP	M2
R281			RK73GB1J102J	CHIP R 1.0K J 1/16W		D26			HVC350B	VARI CAP	M3
R282			RK73GB1J684J	CHIP R 680K J 1/16W		D27			MA2S111	DIODE	
R283			RK73GB1J184J	CHIP R 180K J 1/16W		D28			HVC350B	VARI CAP	M,M3
R285			RK73GB1J681J	CHIP R 680 J 1/16W		D28			HVC355B	VARI CAP	M2

PARTS LIST

TX-RX UNIT (X57-6300-XX)

Ref. No.	Address	New parts	Parts No.	Description	Destination	Ref. No.	Address	New parts	Parts No.	Description	Destination
D30			MA4PH633	DIODE		Q32			DTC363EU	DIGITAL TRANSISTOR	
D31,32			XB15A709	DIODE		Q33			KTA1664(Y)	TRANSISTOR	
D34			MA742	DIODE		Q34,35			KRC102S	DIGITAL TRANSISTOR	
D36			MA742	DIODE		Q37,38			KRC404RTK	DIGITAL TRANSISTOR	
D38			ZSH5MA27	SURGE ABSORBER		Q39			2SC5108(Y)	TRANSISTOR	
D39			02DZ18(X,Y)	ZENER DIODE		Q41			2SC4919	TRANSISTOR	
D41			1812L110PR	VARIATOR		Q42			2SA1641(S,T)	TRANSISTOR	
D43			DAN222	DIODE		Q43			2SK1824	FET	
D44			1SS372	DIODE		Q101			KTA1046(Y)	TRANSISTOR	
IC1			MB15A02	MOS IC		TH1-3			S1R104J475H	THERMISTOR	
IC3			M62363FP	MOS IC		TH5			S1R104J475H	THERMISTOR	
IC4			NJM2902V	MOS IC							
IC5			TK14489V	BI-POLAR IC							
IC6			784214AGC119	MPU	M						
IC6		*	784214AGC125	MPU	M2,M3						
IC7			24LC08BT-ISN	ROM IC							
IC9			LC73872M	MOS IC							
IC10			NJM2902V	MOS IC							
IC11			NJM2904V	MOS IC							
IC12			TA75S01F	MOS IC							
IC14			NJM78L05UA	BI-POLAR IC							
IC15			PST9140NR	MOS IC							
IC17			NJM78L05UA	BI-POLAR IC							
IC18			PST9140NR	MOS IC							
IC19			TC7W74FU	MOS IC							
IC20			KIA7808AF	ANALOG IC							
IC21			NJM2100V	MOS IC							
IC22			NJM2904V	MOS IC							
IC101			S-AU27AH(K1)	POWER MODULE	M2						
IC101			S-AU27AL(K3)	POWER MODULE	M3						
IC101			S-AU27AM(K3)	POWER MODULE	M						
IC102			LA4600	AF POWER AMP							
Q2			2SJ243	FET							
Q3			2SC4649(N,P)	TRANSISTOR							
Q4			2SA1832(GR)	TRANSISTOR							
Q5			2SC4738(GR)	TRANSISTOR							
Q6			2SC4649(N,P)	TRANSISTOR							
Q7			2SJ243	FET							
Q10,11			2SK508NV(K52)	FET							
Q12			KRX102U	TRANSISTOR							
Q13			KRC404RTK	DIGITAL TRANSISTOR							
Q14			2SC4617(S)	TRANSISTOR							
Q15			2SC5108(Y)	TRANSISTOR							
Q16			KRC414RTK	DIGITAL TRANSISTOR							
Q18			2SC2412K	TRANSISTOR							
Q19			2SC4649(N,P)	TRANSISTOR							
Q20			2SC5108(Y)	TRANSISTOR							
Q21			3SK255	FET							
Q22			2SK1824	FET							
Q23			2SC3357	TRANSISTOR							
Q24			2SC4617(S)	TRANSISTOR							
Q25			2SC3357	TRANSISTOR							
Q26			3SK255	FET							
Q27			2SC2412K	TRANSISTOR							
Q29,30			KRC102S	DIGITAL TRANSISTOR							
Q31			2SA1745(6,7)	TRANSISTOR							

EXPLODED VIEW

- A N67-3008-46 PAN HEAD SEMS SCREW
- B N87-2606-46 BRAZIER HEAD TAPTITE SCREW
- C N87-2614-46 BRAZIER HEAD TAPTITE SCREW

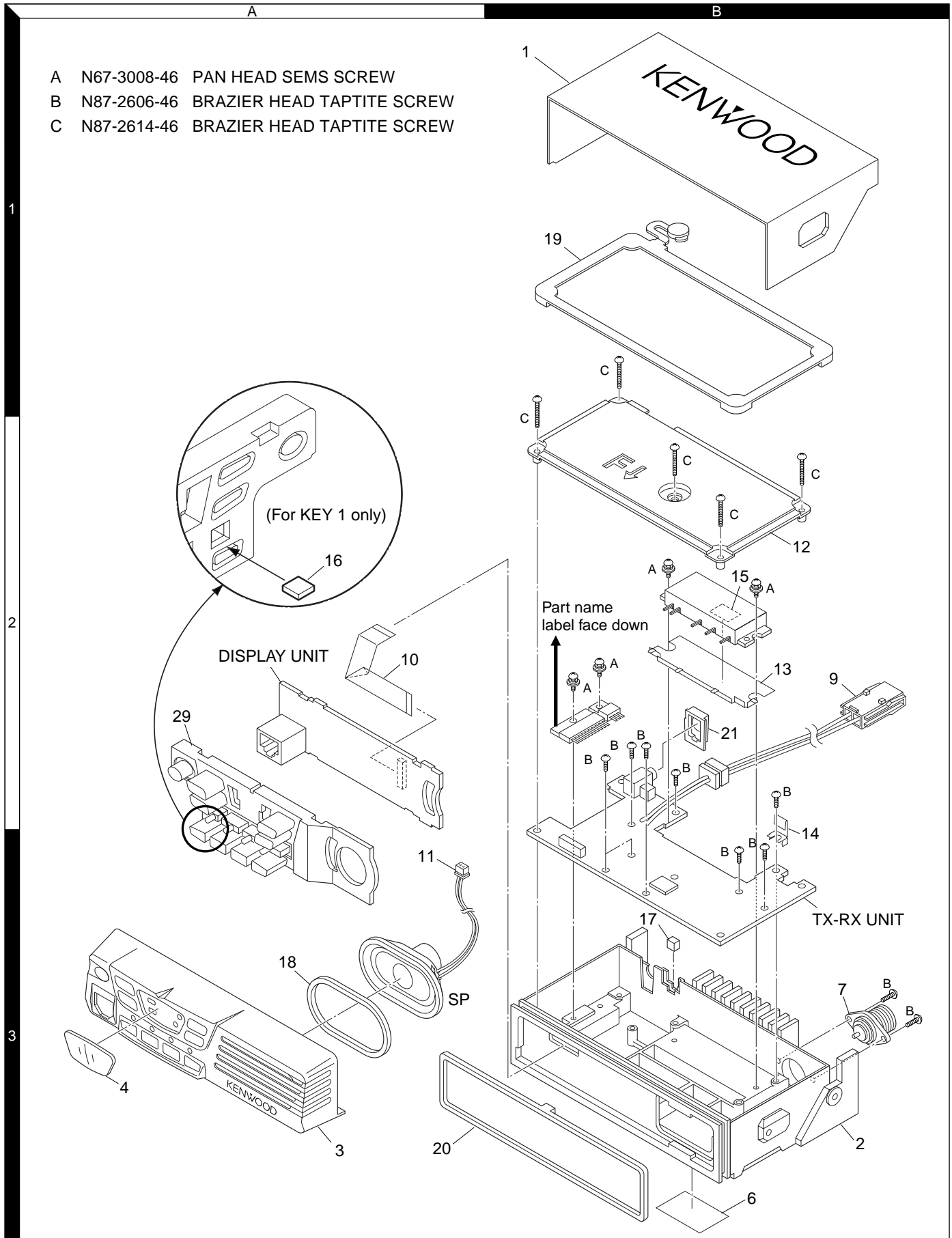

PACKING

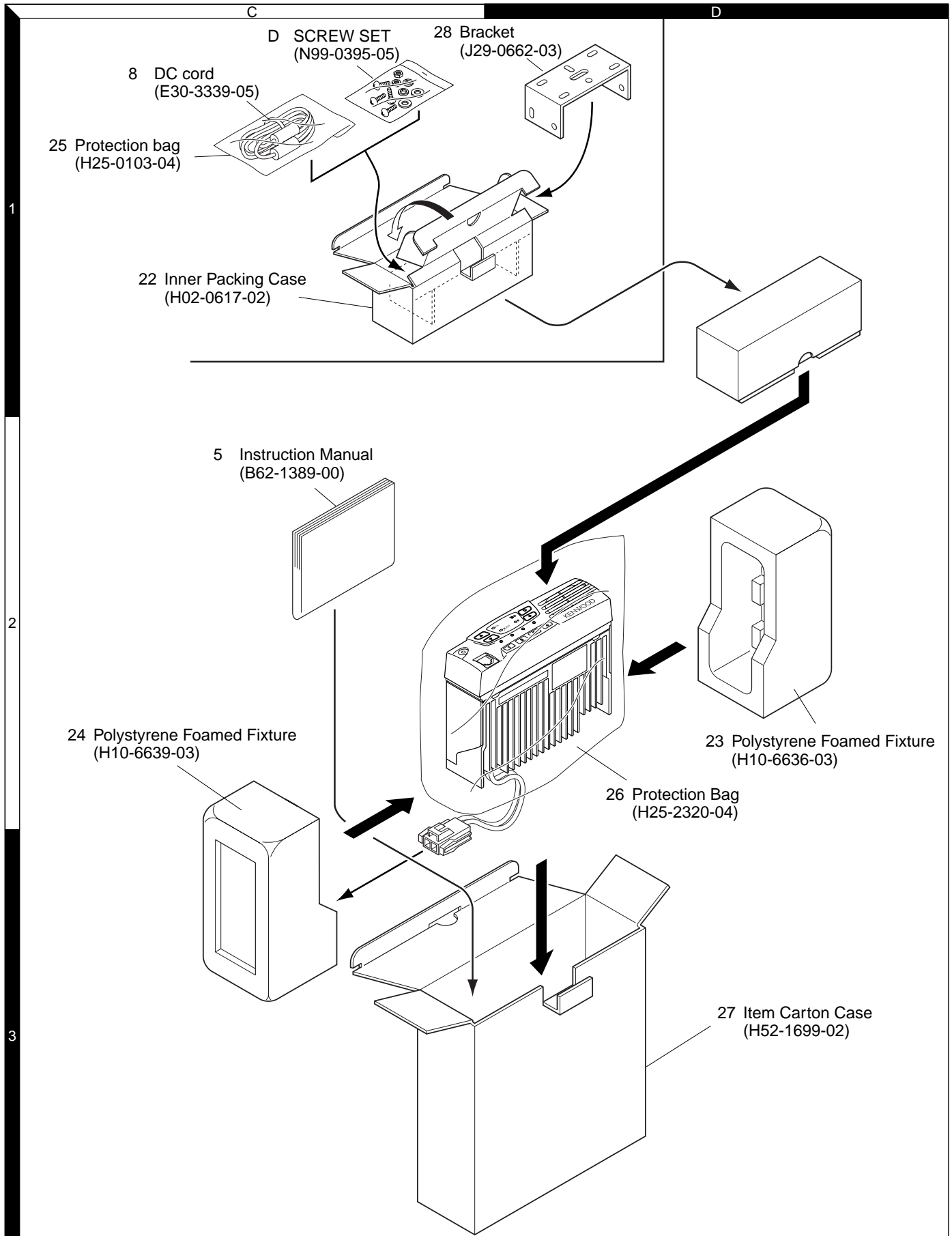

Parts with the exploded numbers larger than 700 are not supplied.

ADJUSTMENT

Test Equipment Required for Alignment

Test Equipment	Major Specifications	
1. Standard Signal Generator (SSG)	Frequency Range Modulation Output	400 to 520MHz Frequency modulation and external modulation -127dBm/0.1μV to greater than -7dBm/100mV
2. Power Meter	Input Impedance Operation Frequency Measurement Capability	50Ω 400 to 520MHz or more Vicinity of 100W
3. Deviation Meter	Frequency Range	400 to 520MHz
4. Digital Volt Meter (DVM)	Measuring Range Accuracy	1 to 20V DC High input impedance for minimum circuit loading
5. Oscilloscope		DC through 30MHz
6. High Sensitivity Frequency Counter	Frequency Range Frequency Stability	10Hz to 1000MHz 0.2ppm or less
7. Ammeter		20A
8. AF Volt Meter (AF VTVM)	Frequency Range Voltage Range	50Hz to 10kHz 1mV to 3V
9. Audio Generator (AG)	Frequency Range Output	20Hz to 20kHz or more 0 to 1V
10. Distortion Meter	Capability Input Level	3% or less at 1kHz 50mV to 10Vrms
11. 4Ω Dummy Load		Approx. 4Ω, 10W or more
12. Regulated Power Supply		13.6V, approx. 20A (adjustable from 9 to 17V) Useful if ammeter requipped
13. Spectrum Analyzer	Center frequency	50KHz to 600MHz
14. Tracking Generator	Output Voltage	100mV or more

Tuning cable (E30-3383-05)

Adapter cable (E30-3383-05) is required for injecting an audio if PC tuning is used. See "PC Mode" section for the connection.

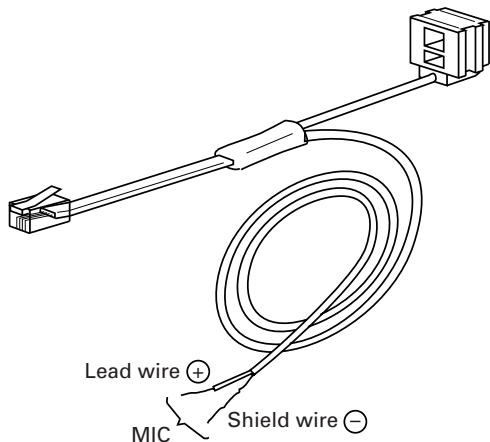

Test cable for microphone input (E30-3360-08)

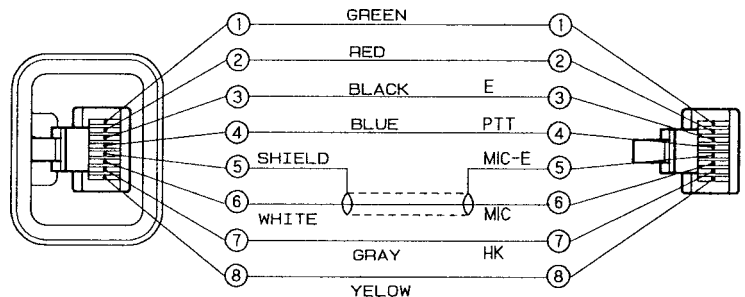

MIC connector (Front view)

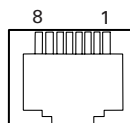

- 1 : BLC
- 2 : PSB
- 3 : E
- 4 : PTT
- 5 : ME
- 6 : MIC
- 7 : HOOK
- 8 : CM

ADJUSTMENT

Adjustment Location

■ Switch

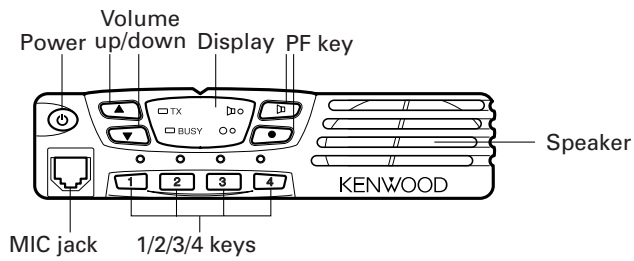

■ Adjustment Point

• Component Side View

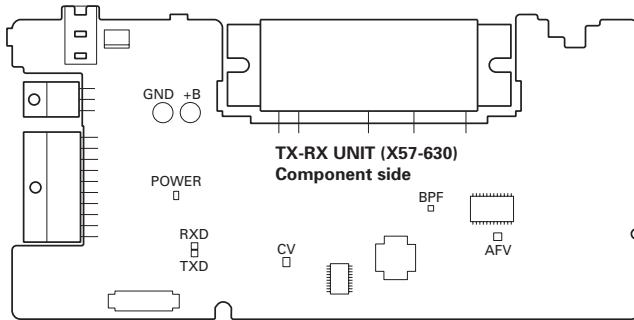

• Foil Side View

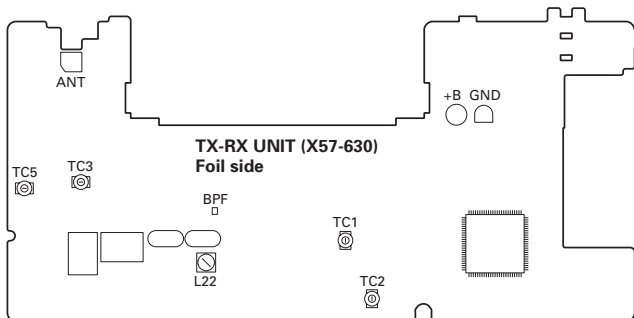

■ Note

• EEPROM

The tuning data (Deviation, Squelch, etc.) for the EEPROM, is stored in memory. When parts are changed, readjust the transceiver.

• AF PA IC (IC102)

How to mounting the IC102.

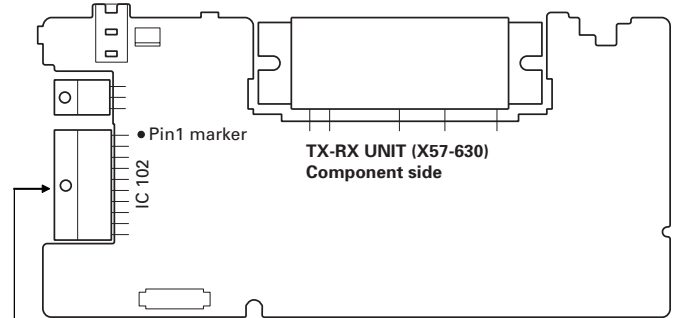

Part name label face down.

• SPEAKER CABLE

The speaker cable should be formed before mounting the shield cover as below.

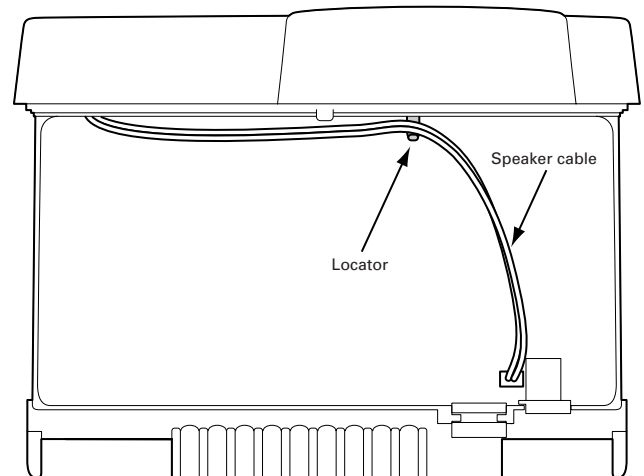

• FUSE

To mount the Fuse, the cable terminal direction must be as follows.

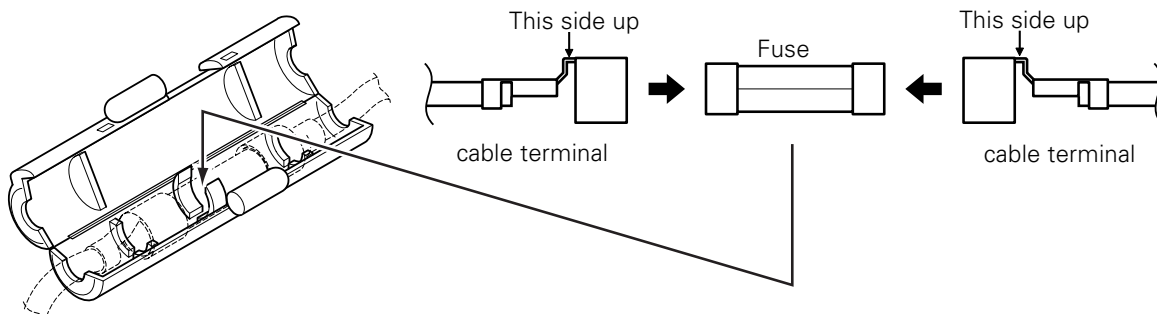

ADJUSTMENT

Use KPG-70D programming software for adjustment of the next items.

PCB Section

Item	Condition	Measurement		Adjustment		Specifications/ Remarks
		Test equipment	Terminal	Parts	Method	
1. Setting	1) Power supply voltage DC Power supply terminal:13.6V					
2. VCO lock voltage	1) CH: TX high	Digital voltmeter	CV	TC2	5.5V	±0.1V
	2) CH: RX high			TC1	5.5V	±0.1V
	3) CH: TX low				Check	0.7V or more
	4) CH: RX low					
3. IF Coil	1) CH: RX center wide 2) SSG output: -53dBm(501uV) Mod: 1kHz, Dev: 3kHz	SSG Digital voltmeter	AFV	L22	3.2~3.3V(DC)	
4. RF Band-pass filter	1) CH: RX center wide CH: RX low wide CH: RX high wide 2) Tra generator output: -30dBm Connect the spectrum analyzer to BPF terminal	Tra generator Spectrum analyzer	ANT BPF	TC3 TC5	Adjust the BPF waveform to Fig.1	

Receiver Section

Item	Condition	Measurement		Adjustment		Specifications/ Remarks
		Test equipment	Terminal	Parts	Method	
1. Sensitivity	1) CH: RX low: Wide/Narrow CH: RX center: Wide/Narrow CH: RX high: Wide/Narrow 2) SSG output: -118dBm(0.28μV): Wide -116dBm(0.35μV): Narrow Mod: 1kHz Dev: ±3.0kHz: Wide Dev: ±1.5kHz: Narrow	SSG Oscilloscope AF. V. M Distortion meter	ANT Ext. SP		Check	SINAD: 12dB or higher
2. Squelch 9	1) CH: RX low: Wide CH: RX center: Wide/Narrow CH: RX high: Wide 2) SSG output: 9dB above to 12dB SINAD level: Wide/Narrow Mod: 1kHz Dev: ±3.0kHz: Wide Dev: ±1.5kHz: Narrow			PC key	Adjust to open the squelch.	
3. Squelch 1	1) CH: RX low: Wide CH: RX center: Wide/Narrow CH: RX high: Wide 2) SSG output: 2dB above to 12dB SINAD level: Wide/Narrow Mod: 1kHz Dev: ±3.0kHz: Wide Dev: ±1.5kHz: Narrow					

Test frequency(MHz)

TK-8102 M

Channel	TX	RX
1: Center	470.100	470.050
2: Low	450.100	450.050
3: High	489.900	489.950
4	470.000	470.000
5	470.200	470.200
6	470.400	470.400

TK-8102 M2

Channel	TX	RX
1: Center	502.600	502.550
2: Low	485.100	485.050
3: High	519.900	519.950
4	502.000	500.200
5	502.200	502.200
6	502.400	502.400

TK-8102 M3

Channel	TX	RX
1: Center	415.10000	415.05000
2: Low	400.10000	400.05000
3: High	429.90000	429.95000
4	415.00000	415.00000
5	415.20000	415.20000
6	415.40000	415.40000

ADJUSTMENT

Transmitter section

Item	Condition	Measurement		Adjustment		Specifications/ Remarks
		Test equipment	Terminal	Parts	Method	
1. Frequency	1) CH: TX center 2) Transmit	Frequency counter	ANT	PC key	Adjust to center frequency	within $\pm 100\text{Hz}$
2. High power	1) CH: TX low CH: TX low' CH: TX center CH: TX high' CH: TX high 2) Transmit	Power meter			25W	$\pm 1.0\text{W}$
3. Low Power	1) CH: TX low CH: TX low' CH: TX center CH: TX high' CH: TX high 2) Transmit				5W	$\pm 0.5\text{W}$
4. DQT balance	1) CH: TX low: Wide CH: TX center: Wide/Narrow CH: TX high: Wide 2) Transmit	Modulation analyzer or linear detector(LPF: 3kHz) Oscilloscope	ANT MIC	Adjust the waveform as below 		
5. Max deviation	1) CH: TX low: Wide CH: TX center: Wide/Narrow CH: TX high: Wide 2) AG: 1kHz/50mV 3) Transmit	Modulation analyzer or linear detector(LPF: 15kHz) Oscilloscope AG		$\pm 4.0\text{kHz}$: Wide	$\pm 50\text{Hz}$	
6. Mic sensitivity	1) CH: TX center: Wide/Narrow 2) AG: 1kHz/5mV 3) Transmit	AF.V.M		$\pm 2.0\text{kHz}$: Narrow	According to the large +,- Check	$\pm 3\text{kHz} \pm 0.2\text{kHz}$: Wide $\pm 1.5\text{kHz} \pm 0.1\text{kHz}$: Narrow
7. QT deviation	1) CH: TX low: Wide CH: TX center: Wide/Narrow CH: TX high: Wide 2) Transmit	Modulation analyzer or linear detector(LPF: 3kHz) Oscilloscope		$\pm 0.75\text{kHz}$: Wide	$\pm 0.05\text{kHz}$	
8. QT deviation	1) CH: TX low: Wide CH: TX center: Wide/Narrow CH: TX high: Wide 2) Transmit			$\pm 0.35\text{kHz}$: Narrow		
9. DTMF deviation	1) CH: TX center: Wide/Narrow 2) Transmit			$\pm 0.75\text{kHz}$: Wide	$\pm 0.05\text{kHz}$	
				$\pm 0.35\text{kHz}$: Narrow		
				$\pm 3.0\text{kHz}$: Wide	$\pm 0.2\text{kHz}$	
				$\pm 1.5\text{kHz}$: Narrow		

Test frequency(MHz)

TK-8102 M

Channel	TX	RX
1: Center	470.100	470.050
2: Low	450.100	450.050
3: High	489.900	489.950
4	470.000	470.000
5	470.200	470.200
6	470.400	470.400

TK-8102 M2

Channel	TX	RX
1: Center	502.600	502.550
2: Low	485.100	485.050
3: High	519.900	519.950
4	502.000	500.200
5	502.200	502.200
6	502.400	502.400

TK-8102 M3

Channel	TX	RX
1: Center	415.10000	415.05000
2: Low	400.10000	400.05000
3: High	429.90000	429.95000
4	415.00000	415.00000
5	415.20000	415.20000
6	415.40000	415.40000

ADJUSTMENT

BPF-Wave

- TK-8102 M

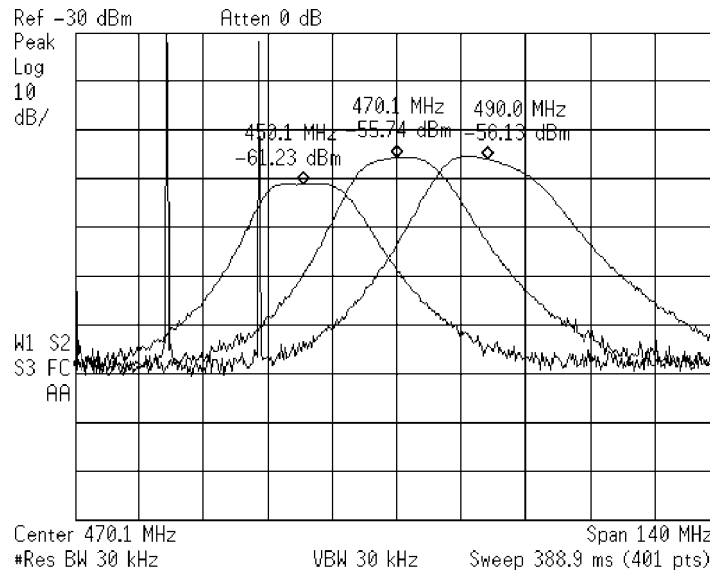

- TK-8102 M2

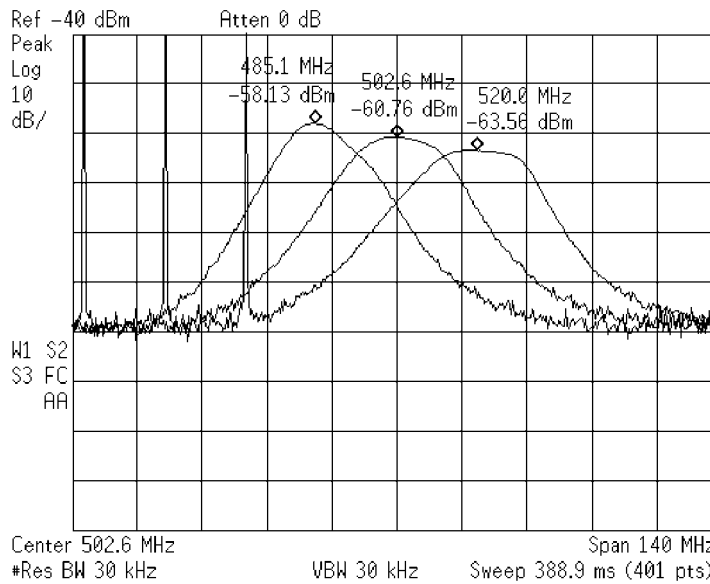

- TK-8102 M3

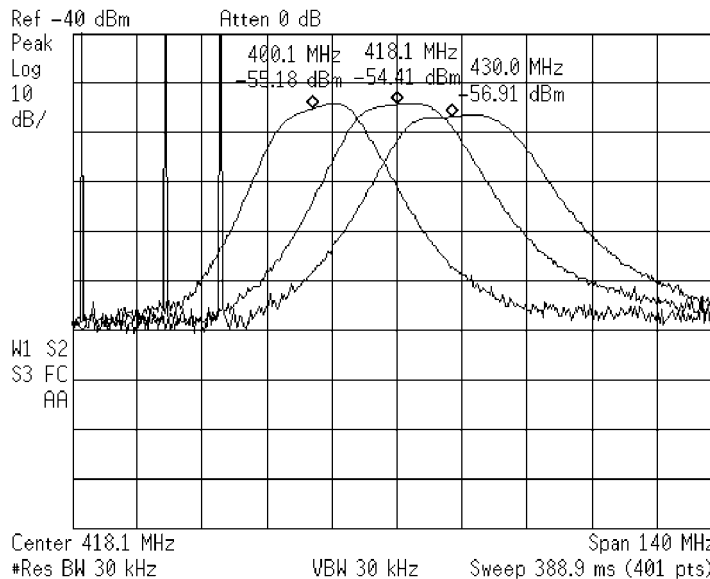

PC BOARD VIEW TK-8102

DISPLAY UNIT (X54-3340-20) Component side view + Foil side view

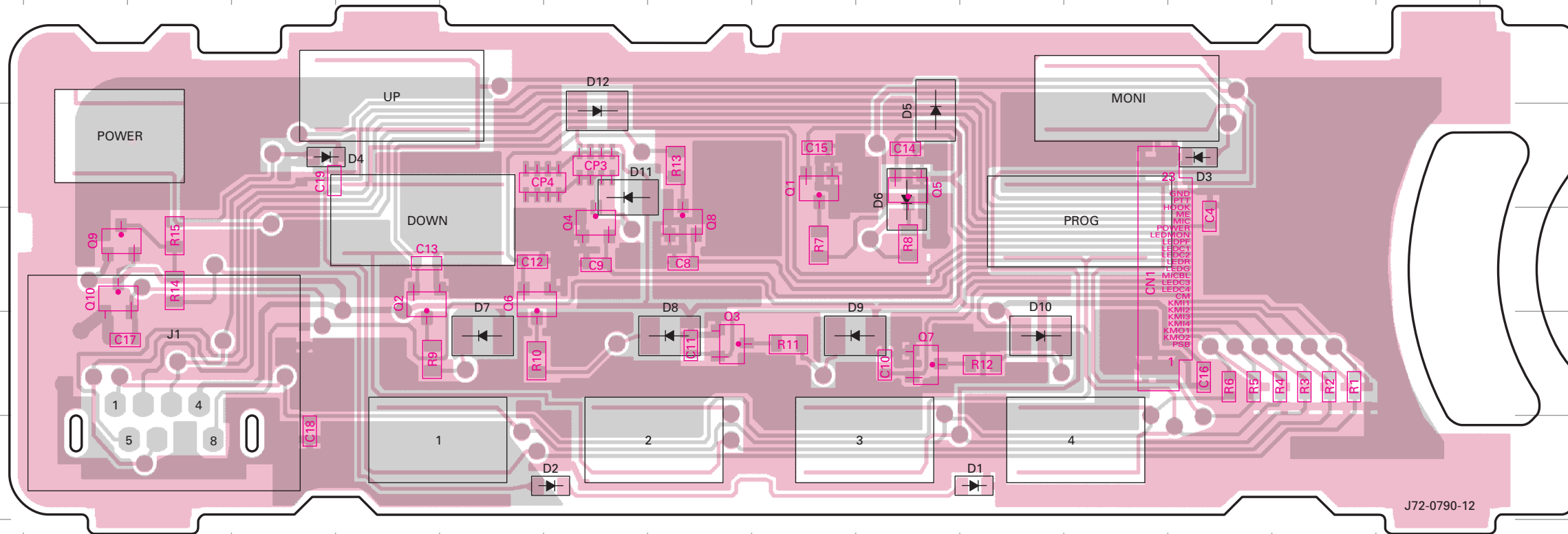

DISPLAY UNIT (X57-3340-20) Component side view

Ref. No.	Address
Q1	4J
Q2	5F
Q3	6I
Q4	5H
Q5	4K
Q6	5G
Q7	6K
Q8	5I
Q9	5C
Q10	5C
D1	7L
D2	7H
D3	4N
D4	4E
D5	4K
D6	4K
D7	6G
D8	6I
D9	6J
D10	6L
D11	4H
D12	4H

Component side
Foil side

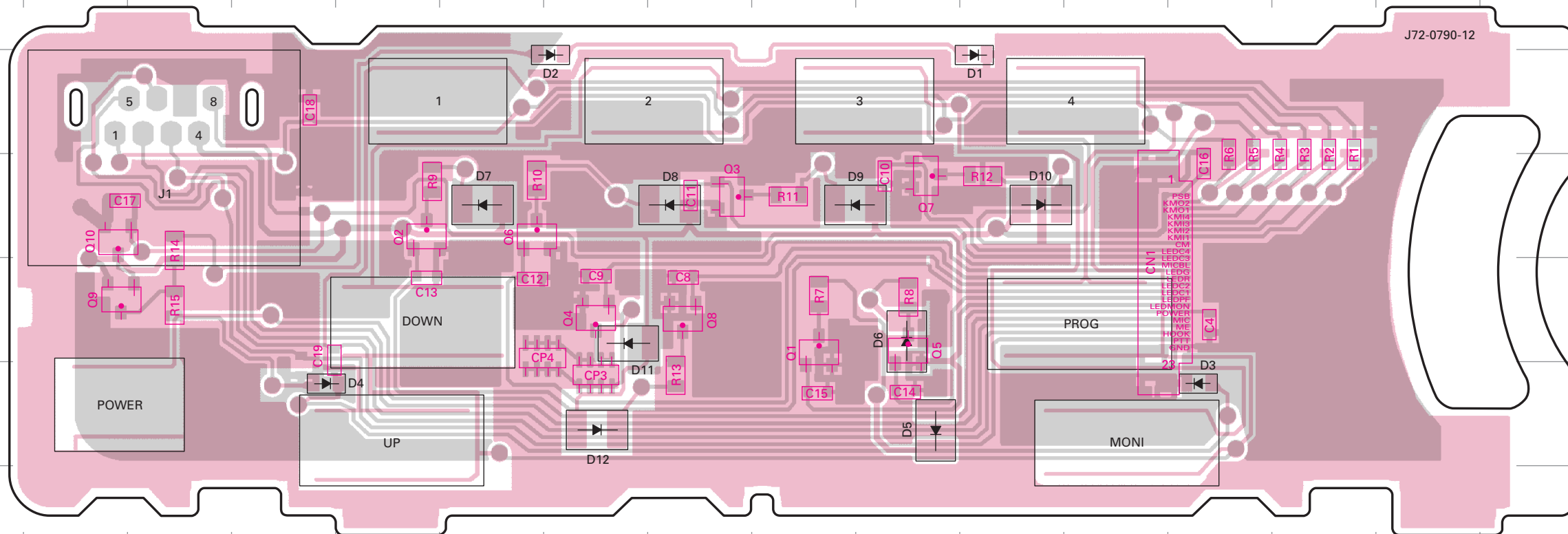

DISPLAY UNIT (X54-3340-20) Foil side view

Ref. No.	Address
Q1	11J
Q2	10F
Q3	10I
Q4	11H
Q5	11K
Q6	10G
Q7	10K
Q8	11I
Q9	11C
Q10	10C
D1	9L
D2	9H
D3	12N
D4	12E
D5	12K
D6	11K
D7	10G
D8	10I
D9	10J
D10	10L
D11	11H
D12	12H

Component side
Foil side

TK-8102 PC BOARD VIEW

TX-RX UNIT (X57-6300-XX) Component side view -20:M, -21:M2, -22:M3

TX-RX UNIT (X57-6300-XX)
Component side view

Ref. No.	Address
IC1	10K
IC3	8O
IC4	10R
IC9	7G
IC12	6R
IC17	10D
IC19	7F
IC21	8Q
IC22	8Q
IC101	5L
IC102	8D
Q2	9J
Q4	10J
Q5	10J
Q6	11M
Q16	8H
Q19	10O
Q22	9H
Q27	5F
Q30	10E
Q32	8E
Q33	10D
Q34	5E
Q35	7E
Q38	7F
Q41	8P
Q42	4G
Q43	9H
Q101	5D
D1	11G
D2	10G
D3	10H
D4	9E
D6	9K
D7	10J
D13	9P
D15	9P
D27	5F
D34	6P
D39	6E
D41	4F
D43	8P
D44	8P

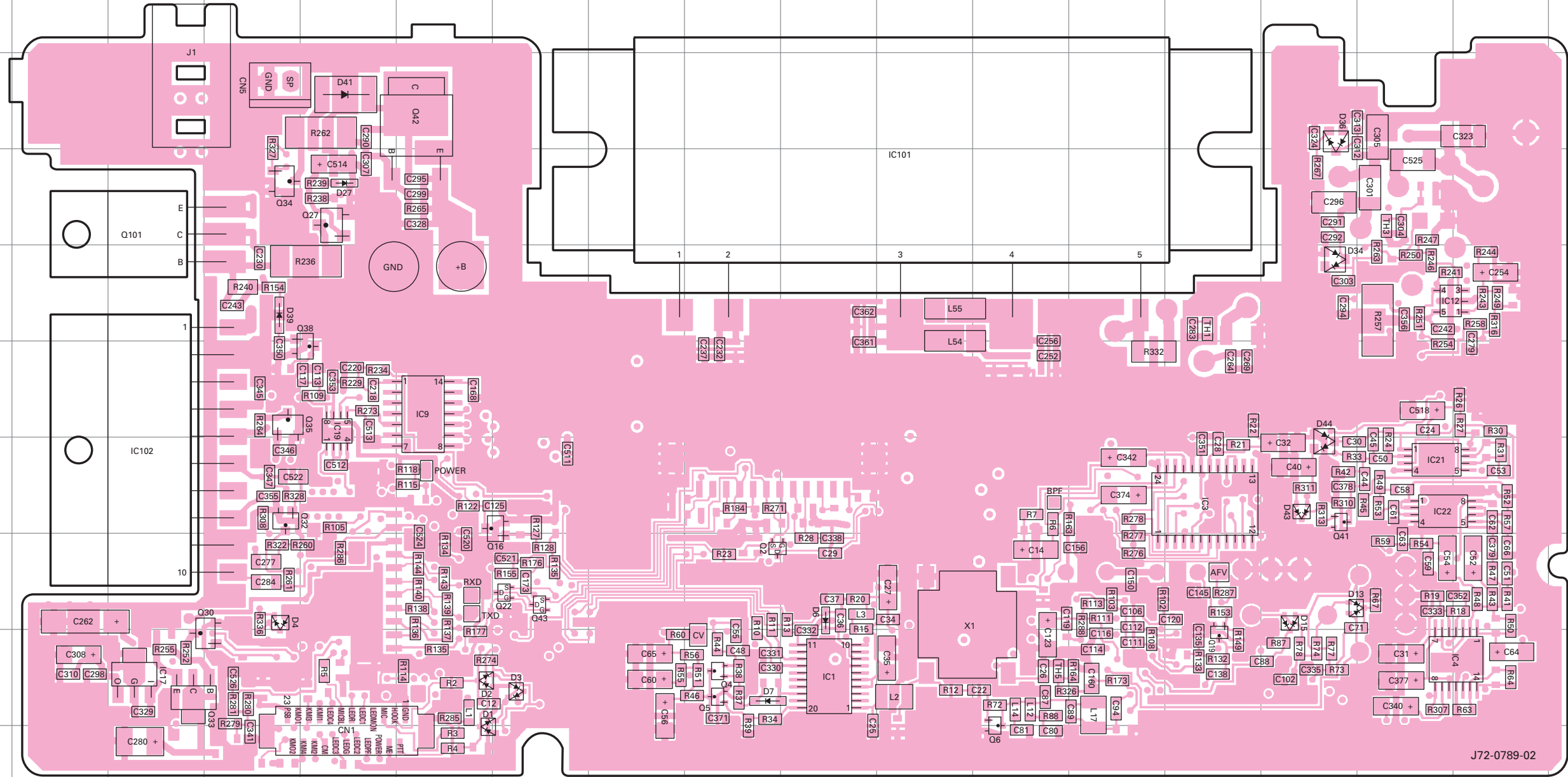

J72-0789-02

Component side

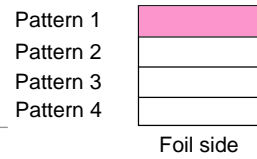

Foil side

LA4600

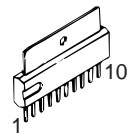

NJM2902V

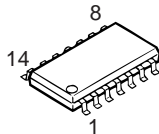

24LC08BT-ISN

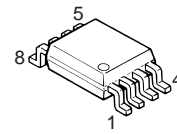

784214AGC119
784214AGC125

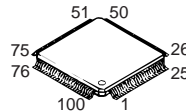

KRX102U

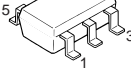

3SK255

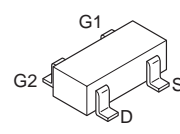

KRC404RTK
KRC414RTK
2SA1745
2SA1832
2SC2412K
2SC4617
2SC4738
2SC5108



2SC3357
2SC2954

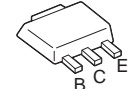

2SA1641

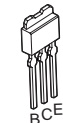

KTA1664



DTC363EU

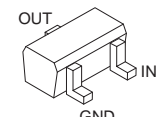

PC BOARD VIEW TK-8102

TX-RX UNIT (X57-6300-XX) Foil side view -20:M, -21:M2, -22:M3

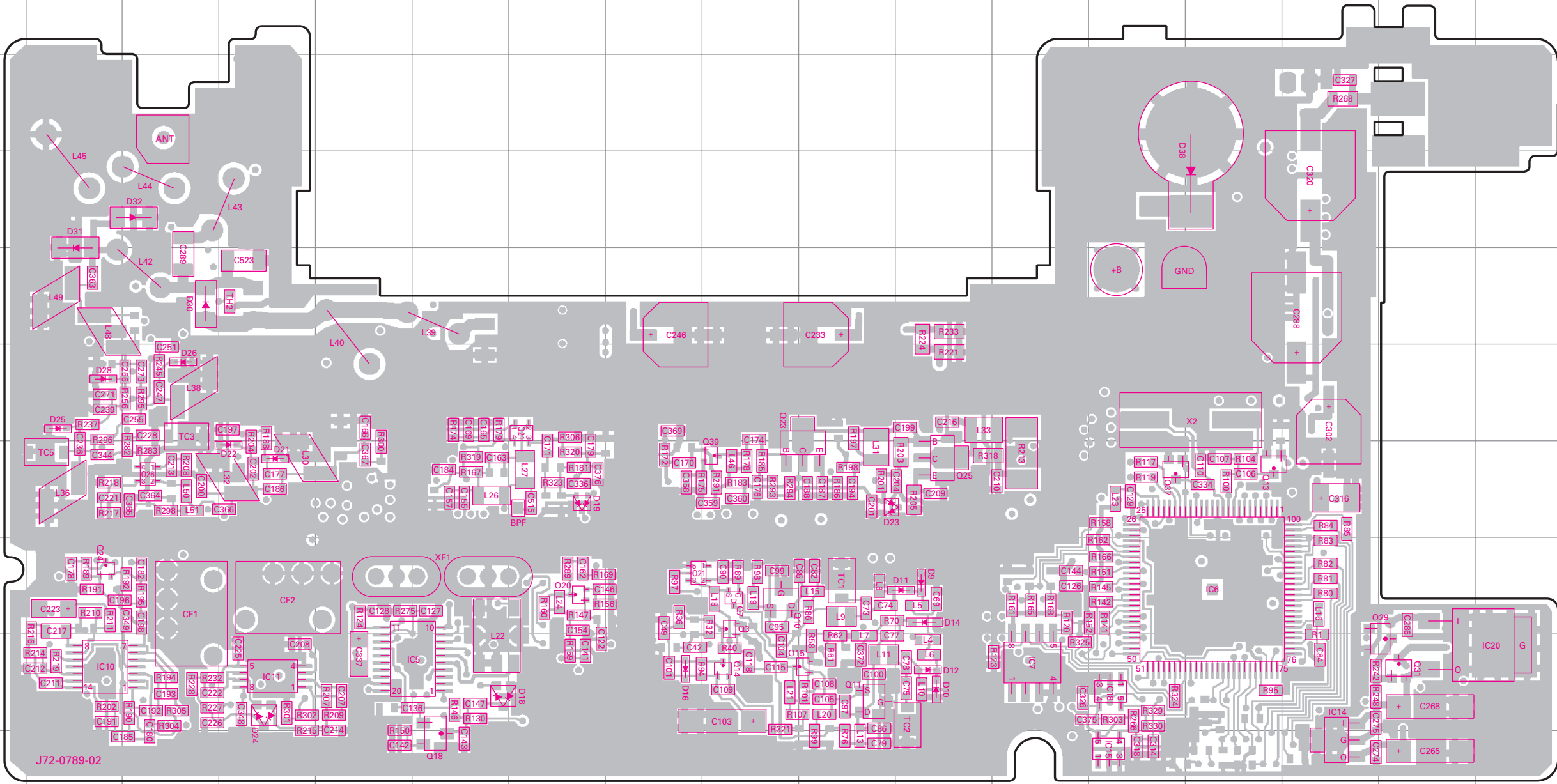

TX-RX UNIT (X57-6300-XX)

Foil side view

Ref. No.	Address
IC5	10F
IC6	9N
IC7	10L
IC10	10B
IC11	10D
IC14	10O
IC15	11M
IC18	10M
IC20	10Q
IC23	10G
Q3	9I
Q7	9I
Q10	9I
Q11	10J
Q12	9H
Q13	8N
Q14	10I
Q15	10J
Q18	11F
Q20	9G
Q21	7G
Q23	8J
Q24	9B
Q25	8K
Q26	8C
Q29	10P
Q31	10P
Q37	8M
Q39	8I
D9	9K
D10	10K
D11	9K
D12	10K
D14	9K
D18	10F
D19	8G
D21	8D
D22	8D
D23	8J
D24	10D
D25	7B
D26	7C
D28	7B
D30	6C
D31	5B
D32	5C
D38	5N

KRA225S
KRC102S

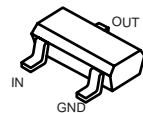

2SC4649
2SC4919

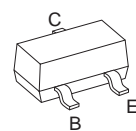

TC7W74FU

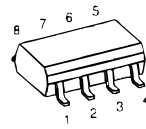

KTA1046

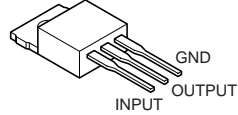

DA221

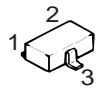

MA742

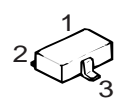

2SK508NV

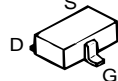

2SJ243

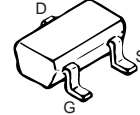

M62363FP

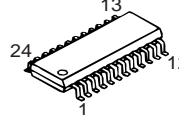

M67741L-35

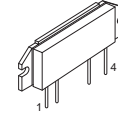

M67741H-32

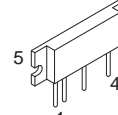

Pattern 1
Pattern 2
Pattern 3
Pattern 4

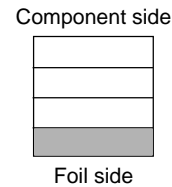

TK-8102 PC BOARD VIEW

TX-RX UNIT (X57-6300-XX) Component side view + Foil side view -20:M, -21:M2, -22:M3

TX-RX UNIT (X57-6300-XX)
Component side + Foil side view

Ref. No.	Address
IC1	10K
IC3	8O
IC4	10R
IC5	10N
IC6	9F
IC7	10H
IC9	7G
IC10	10R
IC11	10P
IC12	6R
IC14	11E
IC15	11G
IC17	10D
IC18	10G
IC19	7F
IC20	10C
IC21	8Q
IC22	8Q
IC27	9L
IC101	5L
IC102	8D
Q2	9J
Q3	9K
Q4	10J
Q5	10J
Q6	11M
Q7	9K
Q10	9J
Q11	10J
Q12	9L
Q13	8F
Q14	10K
Q15	10J
Q16	8H
Q18	11N
Q19	10O
Q20	9M
Q21	7M
Q22	9H
Q23	8J
Q24	9R
Q25	8I
Q26	8I
Q27	5F
Q29	10D
Q30	10E
Q31	10D
Q32	8E
Q33	10E
Q34	5E
Q35	7E
Q37	8G
Q38	7F
Q39	8K
Q41	8P
Q42	4G
Q43	9H
Q101	5D
D1	11G
D2	10G
D3	10H
D4	9E
D6	9K
D7	10J
D9	9I
D10	10I

Ref. No.	Address
D11	9I
D12	10I
D13	9P
D14	9I
D15	9P
D16	10L
D18	10M
D19	8M
D21	8P
D22	8P
D23	8J
D24	10P
D25	7R
D26	7Q

Ref. No.	Address
D27	5F
D28	7R
D30	6Q
D31	5R
D32	5Q
D34	6P
D36	4P
D38	5G
D39	6E
D41	4F
D43	8P
D44	8P

PST9140NR

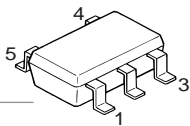

MB15A02

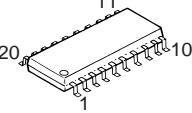

NJM78L05UA

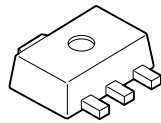

NJM2100V
NJM2904V
UPB1509GV

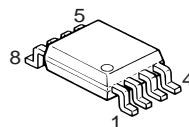

TA75SO1F

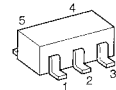

LC73872M

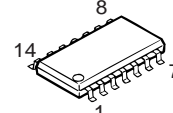

KIA7808AF

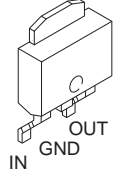

TA14489V

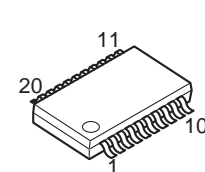

● Connect 1 and 4.

Component side
Pattern 1
Pattern 2
Pattern 3
Pattern 4
Foil side

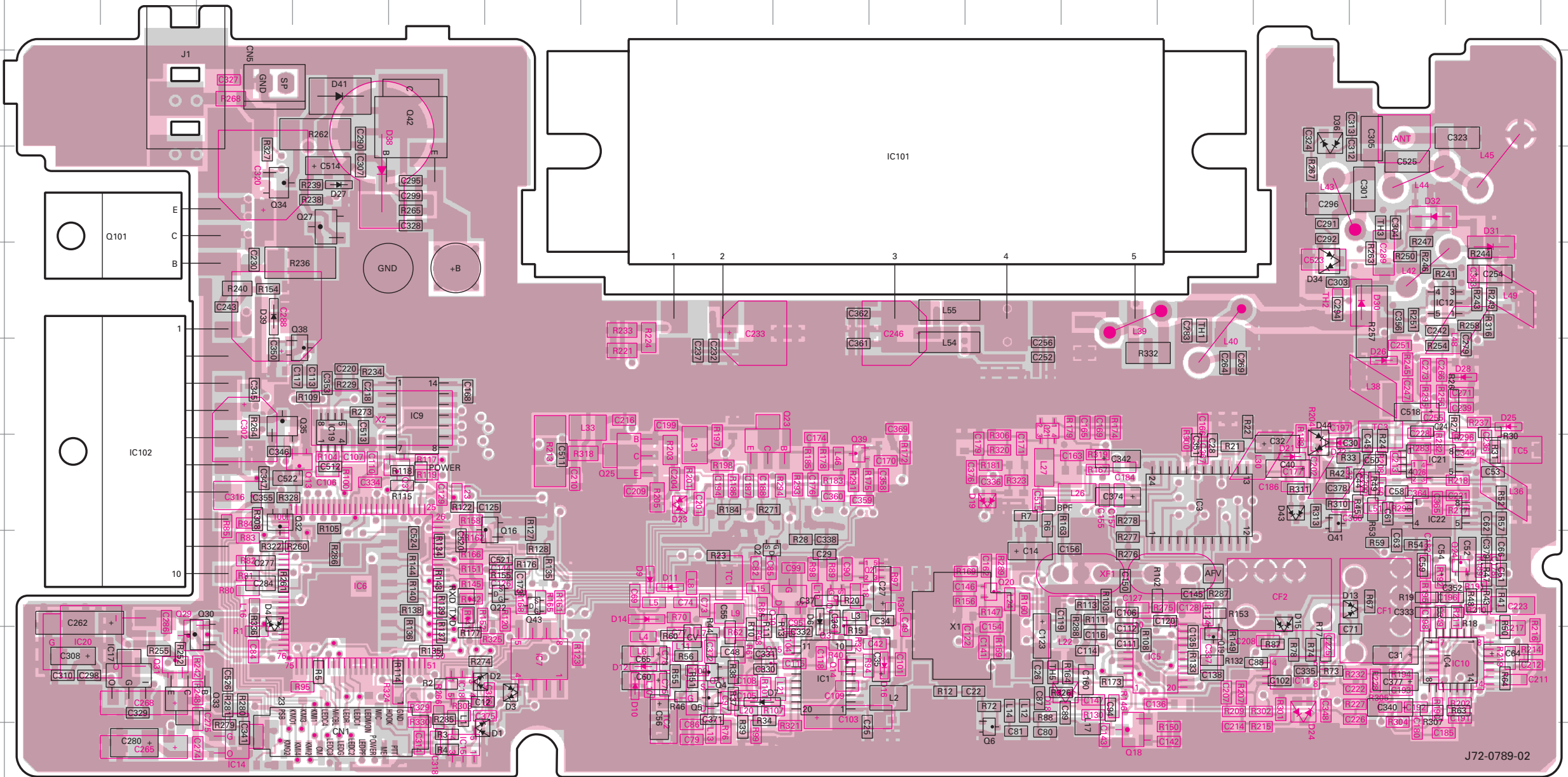

J72-0789-02

SCHEMATIC DIAGRAM

TK-8102

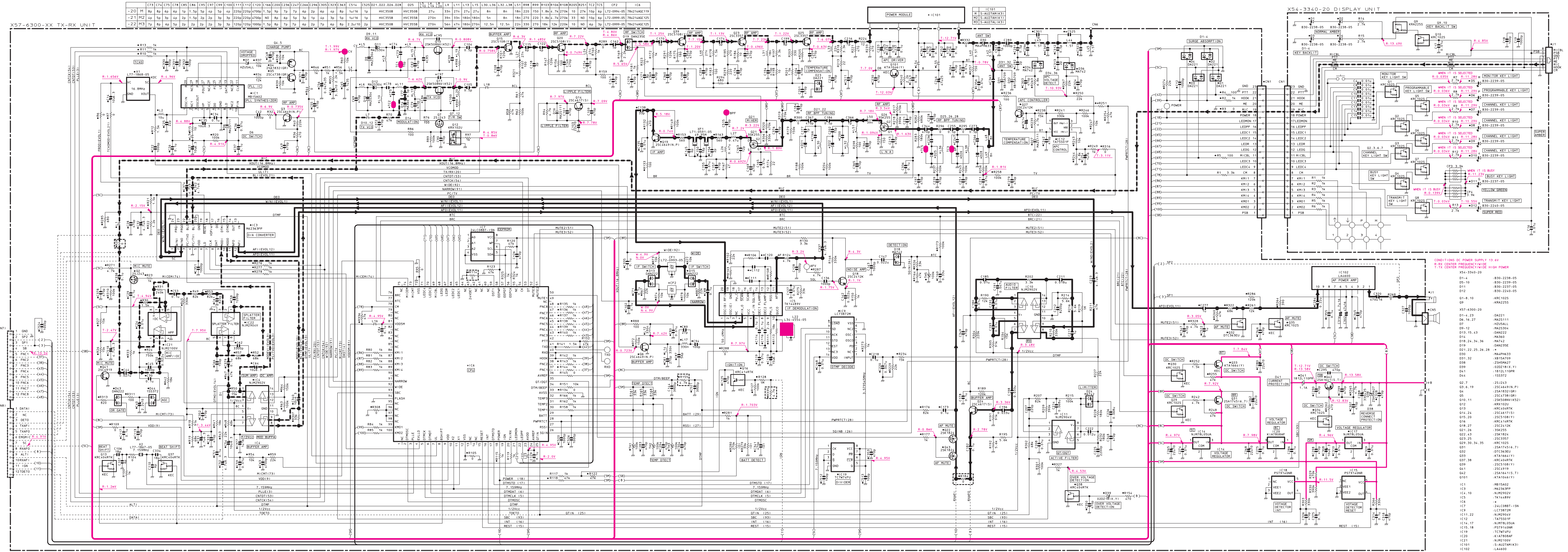

Note : Component marked with a dot (●) are parts of pattern.

TK-8102 TK-8102 BLOCK DIAGRAM

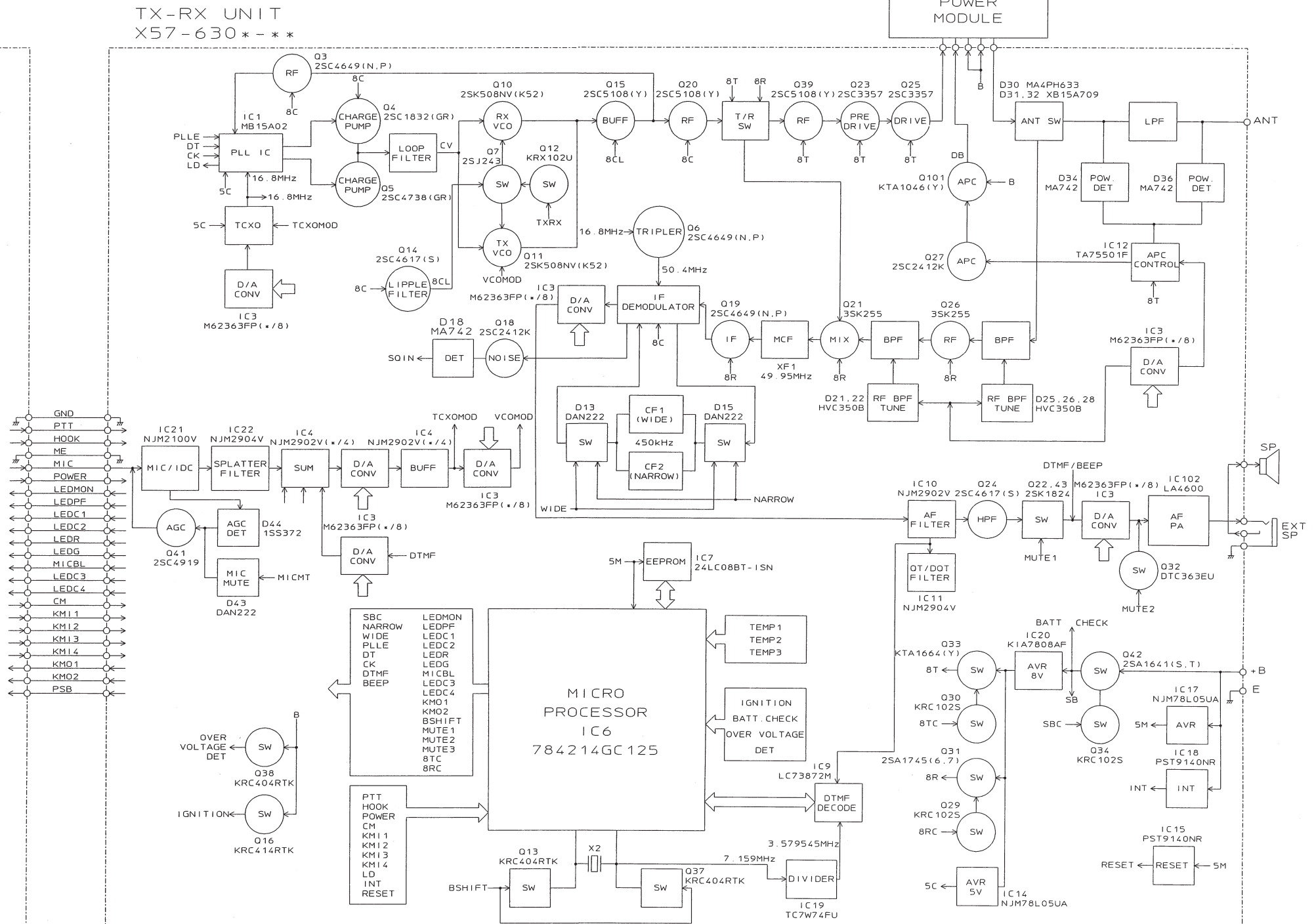
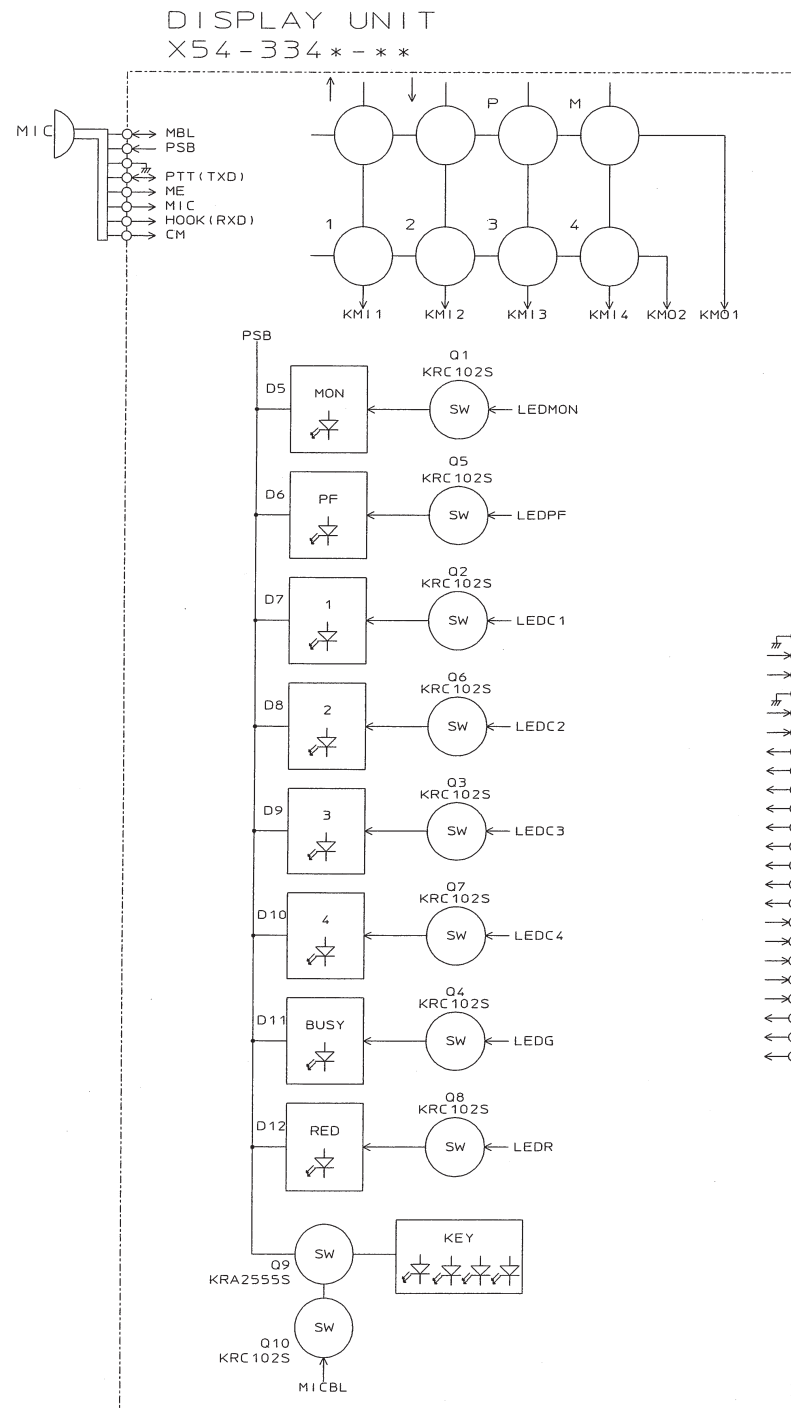

IC101
M: S-AU27AM (K3)
M2: S-AU27AH (K1)
M3: S-AU27AL (K3)

TK-8102 TK-8102 LEVEL DIAGRAM

RX section

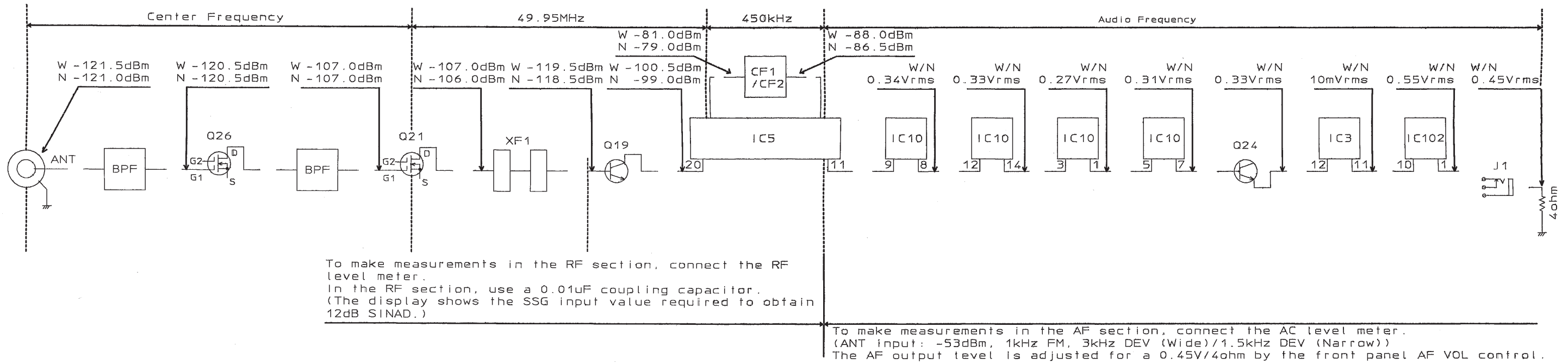

TX section

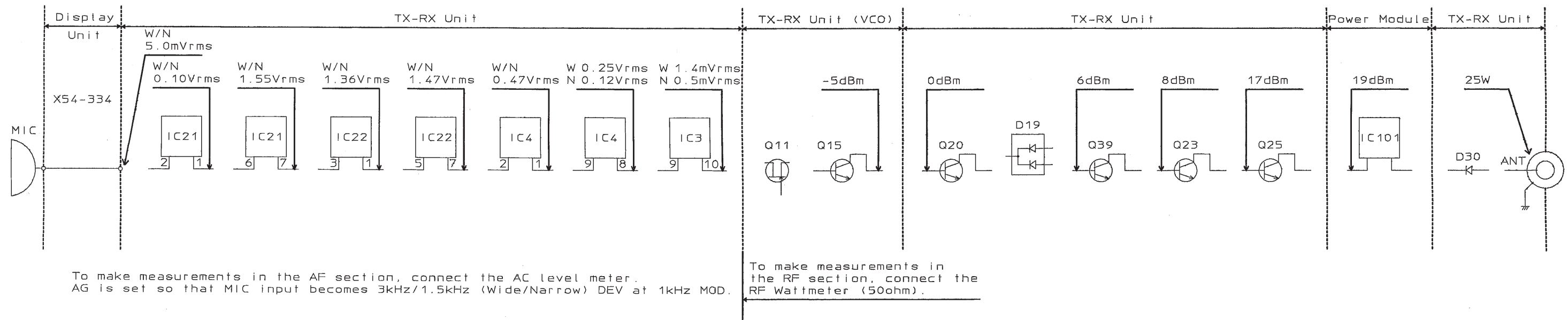

TERMINAL FUNCTION

CN1 (TX-RX Unit)

Pin No.	Name	Function
1	GND	Ground
2	PTT	PTT/TXD
3	HOOK	Hook detection/RXD
4	ME	Mic ground
5	MIC	Mic signal input
6	POWER	Power switch
7	LED MON	Signal of MON Key control
8	LED PF	Signal of PF Key control
9	LED C1	Signal of channel1 control
10	LED C2	Signal of channel2 control
11	LED R	Signal of TX control
12	LED G	Signal of Busy control
13	MICBL	Mic backlight control
14	LED C3	Signal of channel3 control
15	LED C4	Signal of channel4 control
16	CM	Mic data detection
17	KM11	Key matrix input 11
18	KM12	Key matrix input 22
19	KM13	Key matrix input 33
20	KM14	Key matrix input 44
21	KM01	Key matrix input 01
22	KM02	Key matrix input 02
23	PSB	Switched B

J1 (TX-RX Unit)

Pin No.	Name	Function
1	SP	Audio signal output to internal/external speaker.
2	E	Ground

J1 (Control Unit)

Pin No.	Name	Function
1	MBL	MIC backlight control.
2	PSB	13.6V.
3	GND	Ground.
4	PTT/TXD	PTT.
5	ME	MIC ground.
6	MIC	MIC signal input.
7	HOOK/RXD	Hook detection
8	CM	MIC data detection.

TK-8102

SPECIFICATIONS

GENERAL

Frequency Range	M : 450 to 490MHz	M2 : 485 to 520MHz	M3 : 400 to 430MHz
Number of Channels	4 channels		
Channel Spacing	Wide : 25kHz	Narrow : 12.5kHz	
PLL Channel Stepping	5, 6.25kHz		
Operating Voltage	13.6V DC \pm 15%		
Current Drain	Less than 0.4A on standby Less than 1.0A on receive Less than 8.0A on transmit		
Operating Temperature Range	-30°C to +60°C		
Dimensions & Weight	160 (W) x 43 (H) x 107 (D) mm, Approx 1.0kg		
Channel Frequency Spread	M : 40MHz	M2 : 35MHz	M3 : 30MHz

RECEIVER (Measurements made per EIA standard EIA/TIA-603)

Sensitivity (12dB SINAD)	Wide : 0.28 μ V	Narrow : 0.35 μ V
Selectivity	Wide : 75dB	Narrow : 65dB
Intermodulation	Wide : 70dB	Narrow : 60dB
Spurious Response	75dB	
Audio Power Output	4.0W	
Frequency Stability	\pm 2.5ppm	

TRANSMITTER (Measurements made per EIA standard EIA/TIA-603)

RF Power Output	25W	
Spurious and Harmonics	70dB	
Modulation	Wide : 16K0F3E	Narrow : 11K0F3E
FM Noise	Wide : 45dB	Narrow : 40dB
Audio Distortion	Less than 3%	
Frequency Stability	\pm 2.5ppm	

KENWOOD CORPORATION

14-6, Dogenzaka 1-chome, Shibuya-ku, Tokyo 150-8501, Japan

KENWOOD SERVICE CORPORATION

P.O. BOX 22745, 2201 East Dominguez Street, Long Beach, CA 90801-5745, U.S.A.

KENWOOD ELECTRONICS CANADA INC.

6070 Kestrel Road, Mississauga, Ontario, Canada L5T 1S8

KENWOOD ELECTRONICS DEUTSCHLAND GMBH

Rembrücker Str. 15, 63150 Heusenstamm, Germany

KENWOOD ELECTRONICS BELGIUM N.V.

Mechelsesteenweg 418 B-1930 Zaventem, Belgium

KENWOOD ELECTRONICS FRANCE S.A.

13, Boulevard Ney, 75018 Paris, France

KENWOOD ELECTRONICS U.K. LIMITED

KENWOOD House, Dwight Road, Watford, Herts., WD1 8EB United Kingdom

KENWOOD ELECTRONICS EUROPE B.V.

Amsterdamseweg 37, 1422 AC Uithoorn, The Netherlands

KENWOOD ELECTRONICS ITALIA S.p.A.

Via G. Sirtori, 7/9 20129 Milano, Italy

KENWOOD IBERICA S.A.

Bolivia, 239-08020 Barcelona, Spain

KENWOOD ELECTRONICS AUSTRALIA PTY. LTD.

(A.C.N. 001 499 074)

16 Giffnock Avenue, Centrecourt Estate, North Ryde, N.S.W. 2113, Australia

KENWOOD ELECTRONICS (HONG KONG) LTD.

Unit 3712-3724, Level 37, Tower one Metroplaza, 223 Hing Fong Road, Kwai Fong, N.T., Hong Kong

KENWOOD ELECTRONICS TECHNOLOGIES(S) PTE LTD.

Sales Marketing Division

1 Ang Mo Kio Street 63, Singapore 569110

